



KL-0041-521 K / -522 K / -5020

Wheel Bearing Tool (Vito/Viano/Sprinter/Crafter)



Operating instructions EN
 ⚠ Read and understand before use!

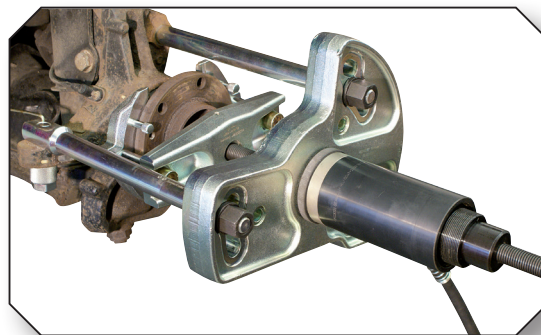

www.gedore-automotive.com

GEDORE Automotive GmbH

Breslauer Straße 41
 78166 - Donaueschingen
 Postfach 1329
 78154 Donaueschingen - GERMANY

☎ +49 (0) 771 / 8 32 23-0
 ☎ +49 (0) 771 / 8 32 23-90
 ✉ info.gam@gedore.com
 🌐 gedore-automotive.com

GEDORE TOOLS, INC.

Only for USA, Canada & Mexico / Sólo para EE.UU., Canadá y México
 Seulement pour les USA, le Canada et le Mexique
 7187 Bryhawke Circle, Suite 700
 North Charleston, SC 29418, USA

☎ +1-843 / 225 50 15
 ☎ +1-843 / 225 50 20
 ✉ info@gedoretools.com
 🌐 gedore.com

Version 04/2023

0041-52..._EN230309.indd



ENGLISH

EN

EN

Address of the manufacturer

GEDORE Automotive GmbH

Breslauer Straße 41 // 78166 Donaueschingen - GERMANY

☎ +49 (0)771/83223-71 // ✉ info.gam@gedore.com

Imprint

In the course of improvement and adaptation to the state of the art, we reserve the right to make changes with regard to appearance, dimensions, weights and properties, and performance.

This does not imply any claim to correction or subsequent delivery of already delivered products. Deletions can be made at any time without any legal claim arising.

Instructions for use and safety are not binding. They never substitute for any legal or trade association regulations.

We do not accept any liability for printing errors.

Any reproduction, in whole or in part, requires the prior written consent of **GEDORE Automotive GmbH**.

All rights reserved worldwide.

© Copyright by **GEDORE Automotive GmbH** Donaueschingen (GERMANY)

We refer to our general terms and conditions, which can be found in the imprint at:

www.gedore-automotive.com



CONTENTS

1. READ AND UNDERSTAND FOR YOUR SAFETY	4
1.1 Target group.....	4
1.2 Obligations of the owner.....	4
1.3 Intended use	4
1.4 Reasonably foreseeable misuse	4
1.5 Personal protective equipment.....	5
1.6 Labelling of the warnings.....	5
1.7 Work environment	5
1.8 Emissions	5
1.9 Basic safety instructions and warnings.....	6
1.10 Maintenance	7
1.11 Troubleshooting.....	7
1.12 Care / storage.....	7
1.13 Repair	7
1.14 Environmentally friendly disposal.....	7
2. PRODUCT DESCRIPTION	8
2.1 KL-0041-52.. - Wheel bearing tool series	8
2.2 Scope of delivery / spare parts overview	10
2.3 Specifications.....	11
3. PREPARATION	12
3.1 Required drive parts	12
3.2 Preparing the vehicle	12
4. TYPICAL APPLICATION	13
4.1 Pulling out the wheel bearing unit on the front axle (rear drive).....	13
4.2 Pressing in the wheel bearing unit on the front axle (rear drive)	19
4.3 Pulling out the wheel bearing and the wheel hub on the front axle (front-wheel/all-wheel drive).....	22
4.4 Pressing in the wheel bearing and the wheel hub on the front axle (front-wheel/all-wheel drive)	28
4.5 Pulling out the wheel hub and the wheel bearing on the rear axle (front-wheel/all-wheel drive).....	32
4.6 Pressing in the wheel bearing and the wheel hub on the rear axle (front-wheel/all-wheel drive).....	35

1. READ AND UNDERSTAND FOR YOUR SAFETY



Read and understand these operating instructions **before using** the wheel bearing tool, and observe all safety and warning instructions! Misuse can result in **DEATH** or **SEVERE INJURIES** ! These operating instructions are an integral part of the wheel bearing tool. Keep them at a safe place for future reference, and always pass them on to subsequent users of the wheel bearing tool! The wheel bearing tool complies with the recognised rules of technology as well as the relevant safety regulations!

1.1 Target group

These operating instructions are **exclusively** intended for skilled personnel in specialised motor vehicle workshops!

The wheel bearing tool **may only be** used by skilled personnel in specialised motor vehicle workshops who are familiar with the basic regulations on work safety and accident prevention!

✔ **Never** allow unauthorised, inexperienced persons, minors and children, or persons with limited physical, sensory, and mental abilities to use the wheel bearing tool!

1.2 Obligations of the owner

Pursuant to the German Ordinance on Industrial Safety and Health (*BetrSichV*), employers are obliged to provide their employees with safe work equipment in accordance with the recognised rules of technology and the relevant safety regulations!

✔ The owner of the wheel bearing tool **must** ensure that **only** trained personnel in specialised vehicle workshops use the wheel bearing tool!

✔ The owner of the wheel bearing tool **must** ensure that the instructions for use are available to the user and that the user has completely read and understood the instructions for use **before** using the wheel bearing tool!

✔ The owner of the wheel bearing tool **must** ensure that the user is familiar with the basic regulations on work safety and accident prevention, and that the personal protective equipment is available to him/her!

1.3 Intended use

The wheel bearing tool ...

✔ **may only** be used for pulling out and pressing in wheel bearing units on vehicles with rear drive and wheel bearings and wheel hubs on vehicles with front-wheel or all-wheel drive!

✔ **may only** be used on vehicles as specified in **Chapter 2 - Product description!**

✔ **may only** be used up to a **max. load of 17 tonnes!**

✔ **may only** be operated by hand with muscle power with a manual drive or a manually operated **GEDORE Automotive** hydraulic cylinder/pump combination with pressure gauge for safe pressure control!

✔ **may only** be used with **GEDORE Automotive** genuine spare parts and accessories!

✔ **may only** be used in the way described in these operating instructions!

⚠ Any other use can result in **DEATH** or **SEVERE INJURIES** !

1.4 Reasonably foreseeable misuse

The wheel bearing tool ...

✔ **must never** be used for pulling out and pressing in other parts or in another way than intended!

✔ **must never** be used together with an impulse or impact screwdriver!

✔ **must never** be used with a machine-operated drive or a machine-operated hydraulic cylinder/pump combination!

✔ **must never** be used with a drive other than that intended for it!

✔ **must never** be used for batch processing (numerous pressing in/out processes within a few minutes)!

✔ **must never** be used with a bridged, modified, or removed safety device!

✔ **must never** be modified, converted, or used for other purposes without authorisation!

⚠ Use the wheel bearing tool **always** as intended. Any other use can result in **DEATH** or in **SEVERE INJURIES**!

1.5 Personal protective equipment

For your safety **always** wear personal protective equipment when using the wheel bearing tool! The wheel bearing tool can bring about mechanical hazards, such as crushing, cutting and shock injuries.



Wear **EYE PROTECTION** (for example to DIN EN 166, OSHA 29 CFR 1910.133, ANSI Z87) when using the wheel bearing tool to protect yourself against flinging parts or particles!

When using the wheel bearing tool, flying parts or particles can cause **SEVERE INJURIES** to your **eyes**!



Wear **PROTECTIVE GLOVES** (for example to DIN EN 388, OSHA 29 CFR 1910.138, ANSI 105) when using the wheel bearing tool to protect yourself against sharp edges and crushing between parts!

When working with the wheel bearing tool, sharp edges and crushing between parts can cause **SEVERE INJURIES** to your **hands**!



Always wear **SAFETY SHOES** (for example to DIN EN ISO 20345, OSHA 29 CFR 1910.136, ANSI Z41) when using the wheel bearing tool to protect yourself against dropping parts!

When working with the wheel bearing tool, dropping parts can cause **SEVERE INJURIES** to your **feet and toes**!

EN

1.6 Labelling of the warnings

Warnings warn of potential **hazards**. **Always** observe these warnings to avoid **DEATH** or **INJURIES**!

For better differentiation, warnings in these operating instructions are classified as follows:

Warning sign	Meaning
	Indicates a hazardous situation, which, if not avoided, could cause DEATH or SERIOUS INJURIES .
	Indicates a hazardous situation which, if not avoided, could cause MODERATE or MINOR INJURIES .
	Indicates a situation which, if not avoided, could cause damage to the tool or an object in its vicinity.
	Note on important information and useful tips.

1.7 Work environment

For your safety **only** use the wheel bearing tool in a safe working environment.

- When using the wheel bearing tool, the workplace **must** be clean and tidy.
- The workplace **must** be sufficiently large and illuminated.
- The workplace **must** be on a solid and non-skidding floor.
- The workplace **must** be safeguarded against access of unauthorised persons.
- The workplace **must** be at room temperature between -10°C and +40°C.

1.8 Emissions

Molybdenum disulphide paste and hydraulic oil can ES drip or escape when using the wheel bearing tool and thus pose a hazard to the environment.

- Immediately** remove leaking hydraulic oil as well as excess molybdenum disulphide paste (using oil binding agents or a cleaning cloth, for example).
- In case of skin contact with hydraulic oil, clean the affected area **immediately** with degreasing soap and water.
- Dispose of pollutants such as hydraulic oil and molybdenum disulphide paste **always in an environmentally friendly manner**.
- Safety data sheets *in accordance with Regulation (EC) No. 1907/2006*, for hydraulic oil (**Alsus Hyd HLP 32**) as well as for molybdenum disulphide paste (**MOLYKOTE® G-N PLUS PASTE**) can be found on the manufacturer's site on the Internet (**World Wide Web**) or, if required, contact **GEDORE Automotive GmbH**.

1.9 Basic safety instructions and warnings

⚠ WARNING - Failure to observe this warning may result in an accident or death.

When using the wheel bearing tool, **always** observe the following safety and warning instructions as well as measures to avoid **DEATH** or **SERIOUS INJURY** as well as property damage due to hazards, misuse, abuse and unsafe handling!

- ✔ Read and understand these operating instructions **before using** the wheel bearing tool, and observe all safety and warning instructions for **safe use!**
- ✔ **Always** work with the wheel bearing tool in accordance with the basic regulations on work safety, accident prevention and environmental protection!
- ✔ **Always** use the wheel bearing tool as intended. **GEDORE Automotive GmbH** accepts no liability or warranty or guarantee claims for injuries and damage resulting from improper use or failure to observe the safety regulations.
- ✔ **Before each use**, check the wheel bearing tool **carefully** for damage, loose parts, or unauthorised modifications. **Never** use it if you notice any such deficiencies! Professional inspection and repair may only be carried out by specially trained personnel from **GEDORE Automotive GmbH!**
- ✔ **Only** use original spare parts and accessories from **GEDORE Automotive GmbH** for the wheel bearing tool!
- ✔ **Always** observe the vehicle-specific manufacturer's specifications when working with the wheel bearing tool!
- ✔ Secure the wheel bearing tool against falling down and flinging around, for example by holding it or by using the **GEDORE** safety retaining belt - **KL-0040-2590** or, alternatively, the retaining device **KL-0040-258 A!**
- ✔ **Never** use the wheel bearing tool with an impulse or impact wrench or any other drive than intended! Drive it **only** by hand and with muscle power; use a manual drive or a manually operated **GEDORE Automotive** hydraulic cylinder/pump combination with a pressure gauge for safe pressure control!
- ✔ **Never** use the wheel bearing tool for batch processing with numerous forcing in/out processes within a few minutes!
- ✔ **Never** use the wheel bearing tool when you are tired or under the influence of alcohol, drugs, or medication!
- ✔ **If necessary**, carry, lift, and position the SEVERE parts of the wheel bearing tool with the help of a second specialist!
- ✔ **Before using** the wheel bearing tool, make sure that **no** unauthorised persons are in the immediate environment!
- ✔ **Always** observe the **max. loading capacity** when using the wheel bearing tool, and **never** exceed it!
- ✔ **Never** stand in axial extension of the wheel bearing tool when it is under load!
- ✔ Wear your personal protective equipment such as safety goggles, protective gloves, safety shoes during work!
- ✔ Interrupt your work **immediately** if you are unsure about using the wheel bearing tool, and contact **GEDORE Automotive GmbH if necessary!**
- ✔ **Always** make sure that the wheel bearing tool is securely attached to the vehicle!
- ✔ **Never** leave the wheel bearing tool unattended in loaded condition on the vehicle!
- ✔ **Never** hit the wheel bearing tool with a hammer or other objects and **never** clamp it in a vice!
- ✔ **Always** avoid dropping, hitting or knocking the wheel bearing tool, especially when it is under load! **Always** place the tool on a clean shelf or workbench to prevent it from falling down!
- ✔ Prior to each use, check the moving parts and the spindle of the wheel bearing tool for sufficient lubrication. If necessary, lubricate them **only** with molybdenum disulphide paste (for example **GEDORE Automotive - KL-0014-0030!**)
- ✔ Interrupt your work **immediately** if you are unsure about using the wheel bearing tool, and contact **GEDORE Automotive GmbH if necessary!**
- ✔ For safety reasons, ensure that a damaged wheel bearing tool is no longer used! Professional inspection and repair may only be carried out by specially trained personnel from **GEDORE Automotive GmbH!**

1.10 Maintenance

Perform maintenance on the wheel bearing tool **at regular intervals** and **only** when the tool is depressurised and/or de-energised! Poor and improper maintenance can damage the wheel bearing tool, thus causing **DEATH** or **SEVERE INJURIES!**

Prior to each use:

- ✔ **Prior to each use**, check the wheel bearing tool **carefully** for damage, loose parts or unauthorised modifications!
- ✔ **Prior to each use** of the wheel bearing tool, check the spindle for contamination and damage. If necessary, clean them, and subsequently lubricate them **only** with molybdenum disulphide paste! (for example, **GEDORE Automotive - KL-0014-0030**)

Recommended: Every 24 months:

- ✔ Have the wheel bearing tool professionally checked **every 24 months** by authorised **GEDORE Automotive GmbH** specialists!

1.12 Troubleshooting

Always perform troubleshooting on the wheel bearing tool puller when it is depressurised/tension-free.

Problem: Hydraulic oil escapes from the hydraulic coupling between hydraulic cylinder and hand pump.

Reason: Hydraulic coupling contaminated or loose.

Remedy: Clean and retighten the hydraulic coupling. Top up lacking hydraulic oil (**HLP 32**) at the hand pump.

Problem: The hydraulic hand pump does not build up pressure or only very slowly.

Reason: The pressure release valve on the hydraulic hand pump is open or hydraulic oil is missing.

Remedy: Close the pressure release valve on the hydraulic pump completely. Top up lacking hydraulic oil (**HLP 32**) at the hydraulic hand pump.

1.12 Care / Storage

CAUTION

Improper care and storage can damage the wheel bearing tool.

- ✔ Therefore, **never** immerse the wheel bearing tool in water, solvents, or other cleaning liquids.
- ✔ After use, clean all parts with a dry and clean cleaning cloth.
- ✔ Store the wheel bearing tool and the operating instructions at a dry and clean place.

1.13 Repair

⚠ WARNING

Improper repair of wheel bearing tool can result in **DEATH** or **SEVERE INJURIES**.

- ✔ If damage, loose parts or unauthorised modifications have been found on the wheel bearing tool, it must no longer be used for safety reasons!
 - ✔ Repair may only be carried out by specially trained personnel from **GEDORE Automotive GmbH!**
 - ✔ **Only** use original spare parts and accessories from **GEDORE Automotive GmbH** for the wheel bearing tool!
- If necessary, contact us, the **GEDORE Automotive GmbH** for a professional inspection and repair of the wheel bearing tool.

1.14 Environmentally friendly disposal

Dispose of the wheel bearing tool and the packaging material in an environmentally compatible way in accordance with the legal requirements. If necessary, ask your local authorities about environmentally friendly disposal options.

2. Product description

2.1 KL-0041-52.. - Wheel bearing tool series

KL-0041-521 K - Wheel bearing tool Vito/Viano (rear drive)

Suitable for wheel bearing units without centre bore on the front axle with, for example, Mercedes V-Class/Vito (W447) and Vito/Viano (W639) with rear drive.

For quick and professional removal and installation of the wheel bearing unit directly on the vehicle. The particular construction of the tool particularly enables the removal and installation of wheel bearing units without centre bore. Thereby the wheel bearing unit is directly pulled out via the wheel hub and pressed in again damage-free via the outer ring of the wheel bearing.

Currently, only complete steering knuckles with pre-assembled wheel bearing units are offered by the vehicle manufacturer for repair. A wheel alignment required as a result entails further consequential costs. The wheel bearing tool, together with a wheel bearing unit from FAG (Schaeffler Automotive Aftermarket), offers a significantly more cost-effective repair solution.

Necessary accessories

KL-0040-2500 - Hydraulic cylinder 17t

KL-0215-35 M25 - Hand pump 17t



KL-0041-522 K - Wheel bearing tool Vito/Viano (front-wheel/all-wheel drive)

Suitable for wheel bearings and wheel hubs with centre bore on the front and rear axle with, for example, Mercedes V-Class/Vito (W447), Vito/Viano (W639) with front-wheel and all-wheel drive.

In combination with the wheel bearing tool - KL-0041-521 K, for a quick and professional removal and installation of wheel bearing and wheel hub directly on the vehicle.

Necessary accessories

KL-0041-521 K - Wheel bearing tool

KL-0040-2500 - Hydraulic cylinder 17t

KL-0215-35 M25 - Hand pump 17t

Recommended accessories

KL-0174-... - Puller series and KL-0049-300 - Impact extractor

Alternatively: KL-0041-380 A - Wheel hub extractor



KL-0041-5020 - Supplement Sprinter/Crafter (rear drive)

Suitable for wheel bearing units without centre bore on the front axle with, for example, Mercedes Sprinter (906) and VW Crafter (2E/ 2F) with rear drive.

In combination with the wheel bearing tool - **KL-0041-521 K**, for a quick and professional removal and installation of the wheel bearing unit directly on the vehicle. The particular construction of the tool particularly enables the removal and installation of wheel bearing units without centre bore. Thereby the wheel bearing unit is directly pulled out via the wheel hub and pressed in again damage-free via the outer ring of the wheel bearing.

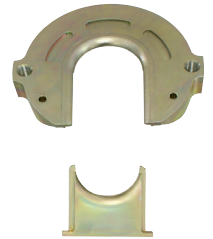

Necessary accessories

- KL-0041-521 K** - Wheel bearing tool
- KL-0040-2500** - Hydraulic cylinder 17t
- KL-0215-35 M25** - Hand pump 17t

KL-4999-2504 E - Supplement "MODULO" Vito/Viano/Sprinter/Crafter (rear/front-wheel/all-wheel drive)

Suitable for wheel bearing units without centre bore as well as common wheel bearings with wheel hubs on the front and rear axle, as for example with Mercedes V class/Vito (W447), Vito/Viano (W639), Mercedes Sprinter (906) and VW Crafter (2E/2F) with rear, front-wheel and all-wheel drive.

Supplement for "MODULO" assembly trolley - KL-4999-250 /-260 /-270

For quick and professional removal and installation of the wheel bearing unit or of the wheel bearing with wheel hub directly on the vehicle. The particular construction of the tool particularly enables the removal and installation of wheel bearing units without centre bore. Thereby the wheel bearing unit is directly pulled out via the wheel hub and pressed in again damage-free via the outer ring of the wheel bearing.

Currently, only complete steering knuckles with pre-assembled wheel bearing units are offered by the vehicle manufacturer for repair. A wheel alignment required as a result entails further consequential costs. The wheel bearing tool, together with a wheel bearing unit from FAG (Schaeffler Automotive Aftermarket), offers a significantly more cost-effective repair solution.



Necessary accessories

- KL-0040-2500** - Hydraulic cylinder 17t
- KL-0215-35 M25** - Hand pump 17t
- KL-0039-1920-1 A** - Pull spindle M20
- KL-0039-1002** - Mounting adapter for clamping nut
- KL-0039-1003** - Mounting adapter for hydraulic cylinder
- KL-0039-1401** - Bearing cover
- KL-0039-1273** - Thrust ring Ø 73mm
- KL-0039-1274** - Thrust ring Ø 74mm
- KL-0039-1502** - Thrust ring Ø 93mm

2.2 Scope of delivery / Overview of the single parts

① The table shows all components of the **KL-0041-52.. - Wheel bearing tool series.**

Prior to using the wheel bearing tool, check to ensure that all the parts included in the scope of delivery are available.

		Wheel bearing tool kits					
		KL-0041-521 K	KL-0041-522 K	KL-0041-5211 K	KL-0041-5212 K	KL-0041-5020	KL-4999-2504 E
Wheel bearing tool individual parts...	Item						
KL-0041-5001 - Base plate	A1	●		●			●
KL-0041-5010 - Adapter 2 1/4"-14 UNS to M42x2mm	A2	●		●			●
KL-0041-5006 - Hex collar nut M18	A3	● 3x		● 3x			● 3x
KL-0041-5004 - Disc, Ø 19mm	A4	● 4x		● 4x			● 4x
KL-0041-5009 - Support rod 275mm	A5	● 2x		● 2x			● 2x
KL-0041-5002 - Support rod with cross hole	A6	●		●			●
KL-0041-5014 M - Taper screw M12	B1	●			●		●
KL-0041-5003- Taper screw M16	B2	●			●		●
KL-0041-5012 - Steering knuckle retaining bracket	C	●			●		●
KL-0041-5005 - Cheese-head screw nut M14 x 70mm	D	● 2x			● 2x		● 2x
KL-0041-5007 - Reinforcement bar 140mm	E1	●			●		●
KL-0041-5008 - Reinforcement bar 196mm	E2	●			●		●
KL-0041-5021 - Bridge with threaded insert	F1	●			●		●
KL-0041-5023 - Cheese-head screw nut M16 x 90mm	F2	● 2x			● 2x		● 2x
KL-0041-5022 - Spacer sleeve Ø 27 x 50mm	F3	● 2x			● 2x		● 2x
KL-0041-5024 - Knurled screw M14x1.5mm	F4	● 3x			● 3x		● 3x
KL-0041-5025 - Retaining pin with O-ring	F5	● 2x			● 2x		● 2x
KL-0041-5030-1 A - Tension / pressure plate for bearing Ø 92mm	G1	●			●		●
KL-0041-5030-2- Closing plate for bearing Ø 92mm	G1.1	●			●		●
KL-0041-5020-1 A - Tension / pressure plate for bearing Ø 96mm	G2					●	●
KL-0041-5020-2- Closing plate for bearing Ø 96mm	G2.1					●	●
KL-0039-1920-1 A - Pull spindle M20	H	●					
KL-0041-5013 - Clamping nut with guide tenon	I1	●			●		●
KL-0041-5041- Clamping nut with insert	I2		●				●
KL-0039-1003 - Mounting adapter for hydraulic cylinder	J		●				
KL-0039-1920-4 - Clamping nut, Ø 38mm	K		●				●
KL-0039-1002 - Mounting adapter for clamping nut	L		●				
KL-0039-1403 - Housing	M		●				●
KL-0039-1401 - Bearing cover	N		●				
KL-0039-1350 - Centring ring Ø 50mm	O1		●				●
KL-0039-1352 - Centring ring Ø 52mm	O2		●				●
KL-0039-1270 - Thrust ring Ø 70mm	P1		●				●
KL-0039-1273 - Thrust ring Ø 73mm	P2		●				
KL-0039-1274 - Thrust ring Ø 74mm	P3		●				
KL-0039-1290 - Thrust ring Ø 90mm	Q1		●				●
KL-0039-1291 - Thrust ring Ø 91mm	Q2		●				●
KL-0039-1502 - Thrust ring Ø 93mm	Q3		●				
KL-0039-1501 - Thrust ring Ø 95mm with recess	Q4		●				●
Storage systems...							
KL-0041-5211-9 - Foam insert	-	●		●			
KL-0041-5212-9 - Foam insert	-	●			●		
KL-0041-5229 - Foam insert	-		●				
KL-4999-2504-9 - Foam insert MODULO	-						●
KL-1010-1069-2 - Packaging for spindle	-	●					
KL-1010-1069-3- Plug for package	-	●					
KL-4600-1094 - Plastic case	-	● 2x	●	●	●		

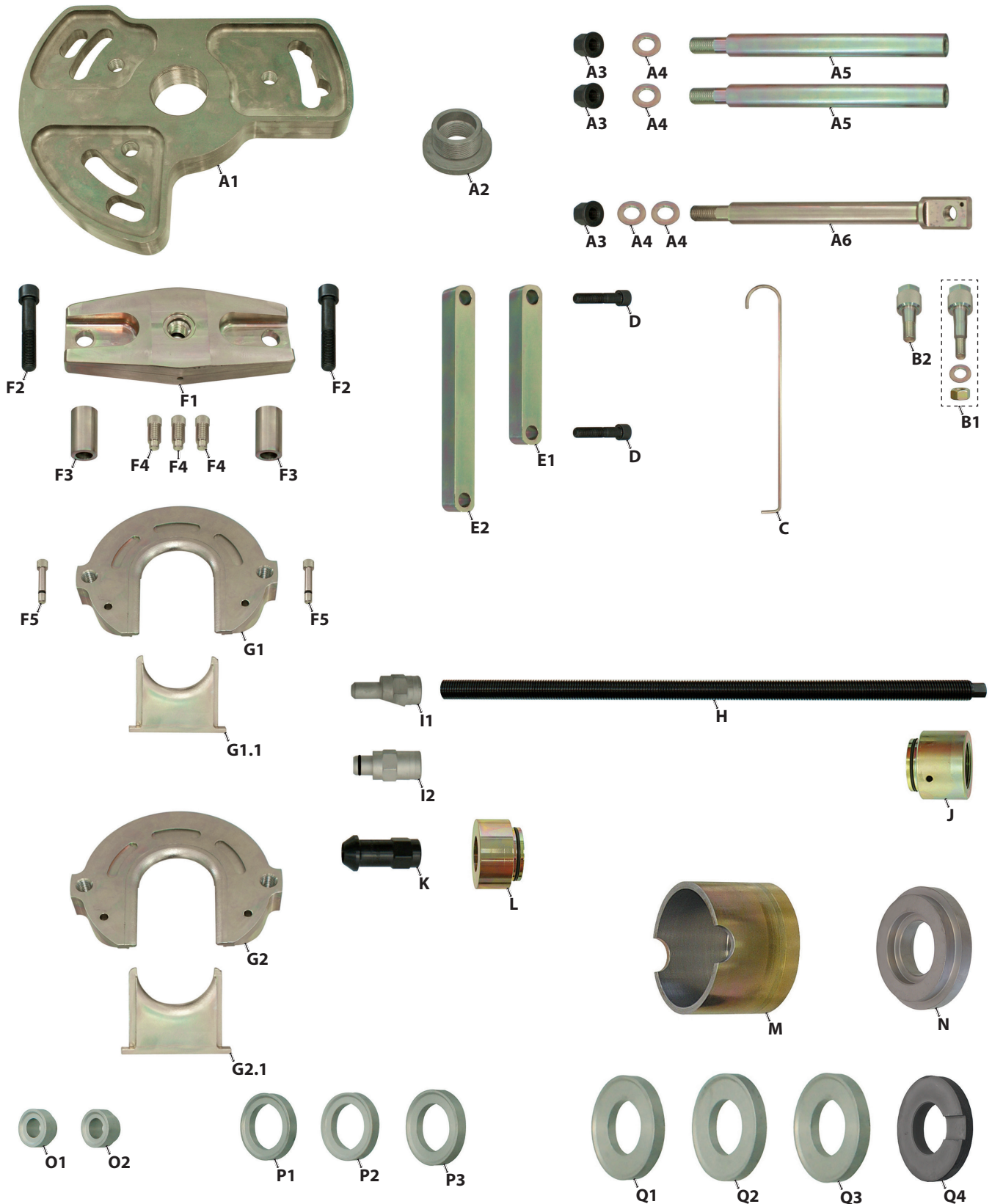

EN

2.3 Specifications

Maximum load capacity: 17 tonnes

3. PREPARATION

3.1 Necessary drive parts

⚠ WARNING

Using a machine-operated drive can cause the wheel bearing tool to slip, break and thus drop or be hurled about. This can cause **DEATH** or **SEVERE INJURIES!**

- The wheel bearing tool must **never** be used with a mechanical drive, e.g. an impulse or impact wrench or a drive other than that intended for it!
- The wheel bearing tool may **only** be driven by hand and with muscle power and a manually operated **GEDORE Automotive** hydraulic cylinder / pump combination with a pressure gauge for safe pressure control!

1. Assemble the required drive parts for the wheel bearing tool as shown in **❶**.

❶ For other drive components and accessories see the **GEDORE Automotive catalogue**.

❶ 1: Assemble the required drive parts...

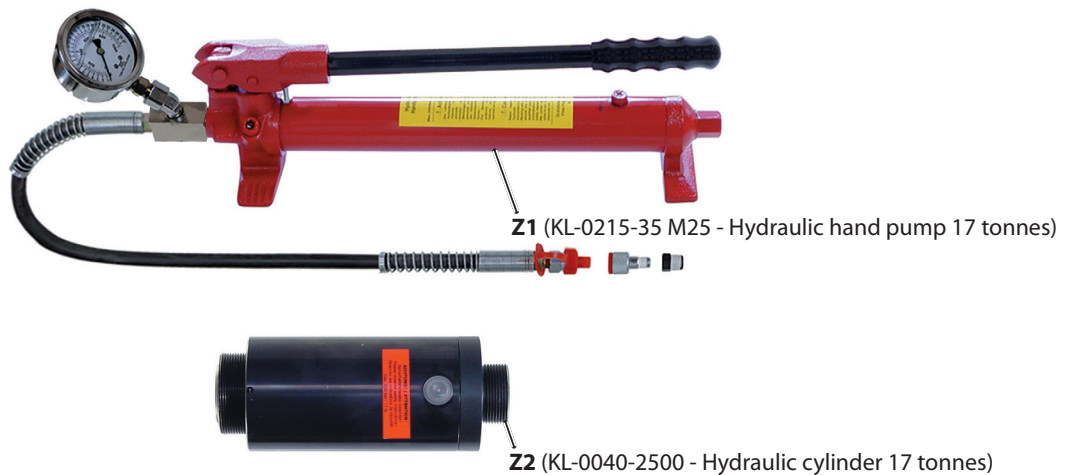

3.2 Preparing the vehicle

❶ 2: Preparing the vehicle...

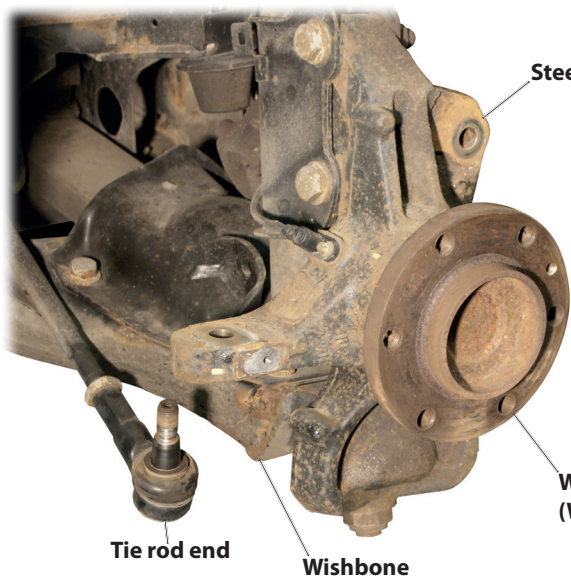

1. Safely lift the vehicle and prepare all necessary parts for the following work in accordance with the manufacturer's specifications.

For example:

Unscrew wheel / remove brake + heat shields / loosen the tie rod end on the steering knuckle / ...

4. TYPICAL APPLICATION

This application example describes the removal and installation directly on the vehicle...

... of a wheel bearing unit without centre bore on the front axle for vehicles with rear drive (see chapter 4.1 / 4.2)

... of a wheel bearing with wheel hub on the front axle for vehicles with front-wheel or all-wheel drive (see chapter 4.3 / 4.4)

...of a wheel bearing with wheel hub on the rear axle for vehicles with front-wheel or all-wheel drive (see chapter 4.5 / 4.6)

4.1 Pulling out the wheel bearing unit on the front axle (rear drive)

3: Select tension / pressure plate [G..] depending on the wheel bearing \emptyset ...

CAUTION

Mercedes V-Class, Vito, Viano, Sprinter and VW Crafter have different wheel bearing \emptyset .

► For wheel bearing \emptyset 92mm the tension/compression plate [G1..] **must** be used and for wheel bearing \emptyset 96mm the tension/compression plate [G2..]!

1. Select the appropriate tension / pressure plate [G1..] or [G2..] depending on the wheel bearing \emptyset .

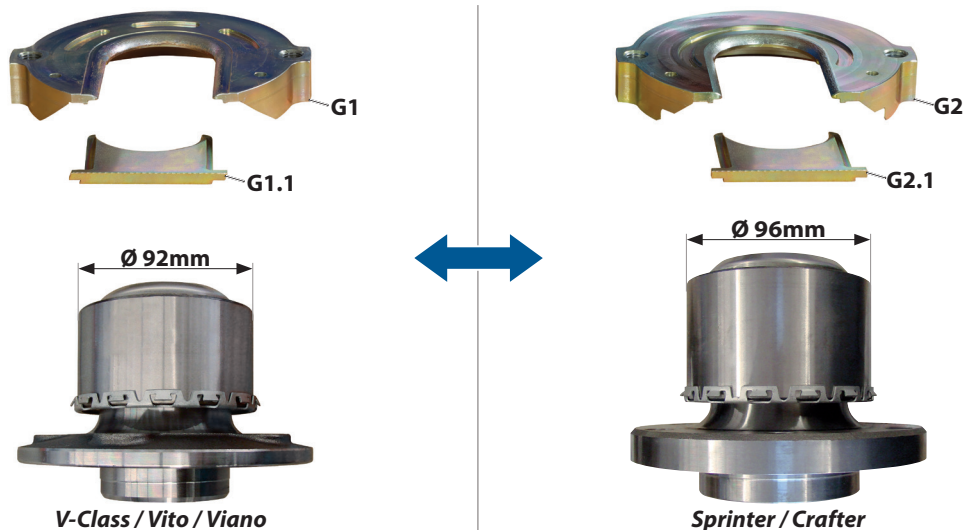

4: Mount the bridge [F..] in the correct position onto the tension / pressure plate [G..]...

2. Mount the bridge [F..] as shown, in the correct position onto the tension / pressure plate [G..] and tighten both screws [F2] with 30Nm.

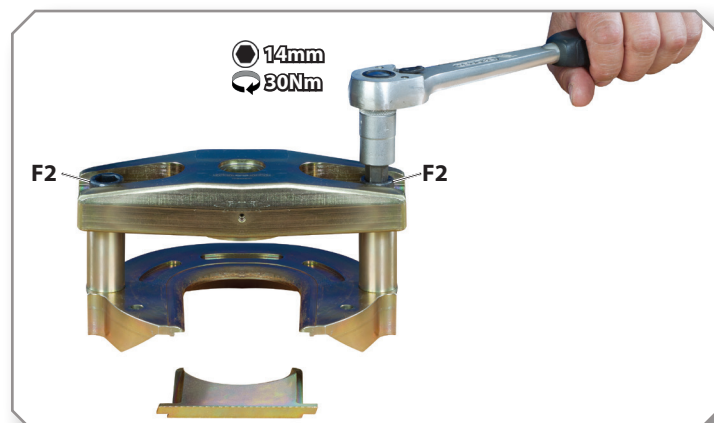
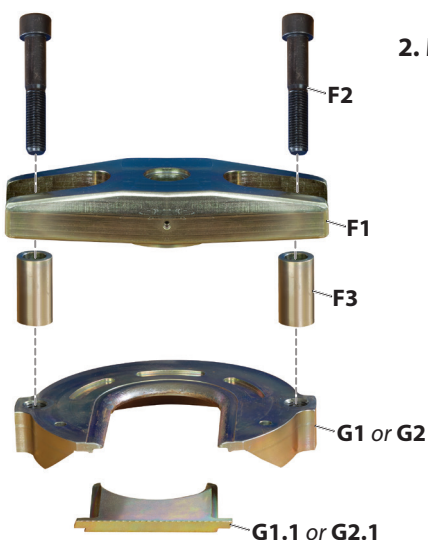

📷 5: Place bridge [F..] with tension/pressure plate [G..] in the correct position over the wheel bearing unit and secure...

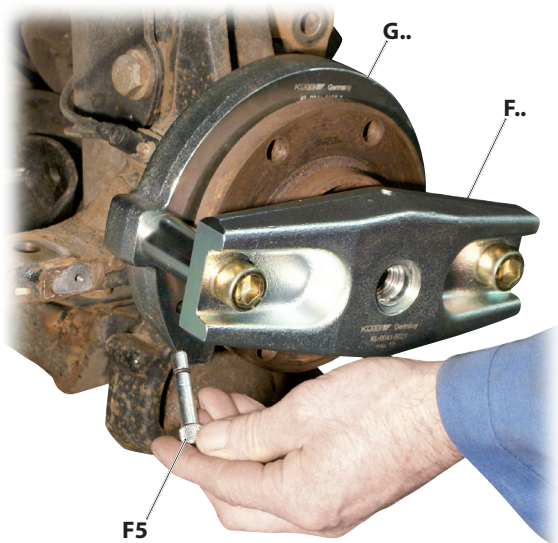

3. Place the bridge [F..] with tension/pressure plate [G..] in the correct position over the wheel bearing unit as shown.

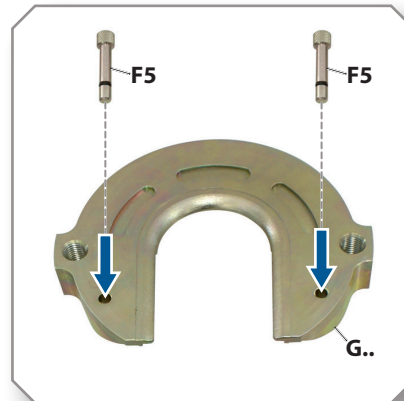

⚠ CAUTION

The wheel bearing unit may fall down during the disassembly process and cause **INJURIES** to the feet.

► The wheel bearing unit **must** always be secured via both retaining pins [F5] at the tension / pressure plate [G..] !

4. To secure the wheel bearing unit, insert both retaining pins [F5] fully into the holes of the tension/pressure plate [G..] as shown.

ⓘ The closing plate [G1.1] or [G2.1] is only required when installing the wheel bearing unit!

📷 6: Mount the support rods [A5] and the reinforcement bar [E..] in the correct position on the steering knuckle...

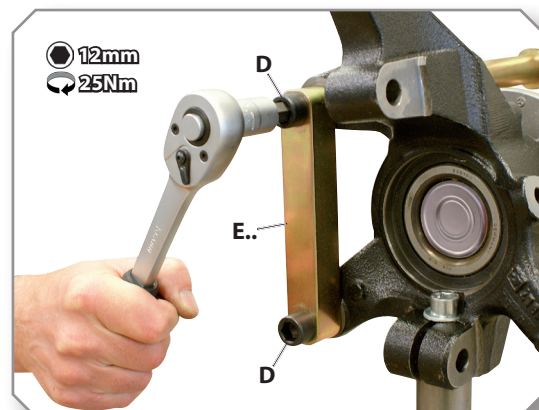
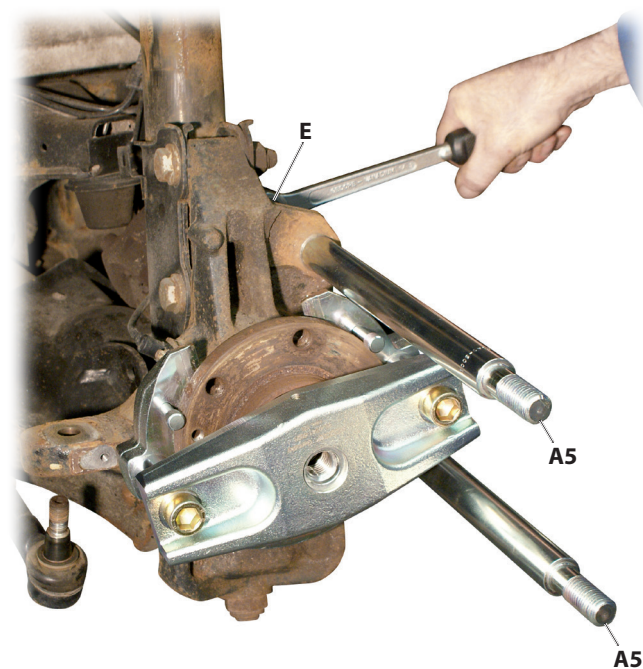

5. Choose the reinforcement bar [E1] or [E2] depending on the hole distance on the steering knuckle.

Screw the appropriate reinforcement bar [E..] together with both support rods [A5] as shown on the steering knuckle and tighten the screws [D] with **25 Nm**.

7: Place one washer [A4] on each of the support rods [A5]...

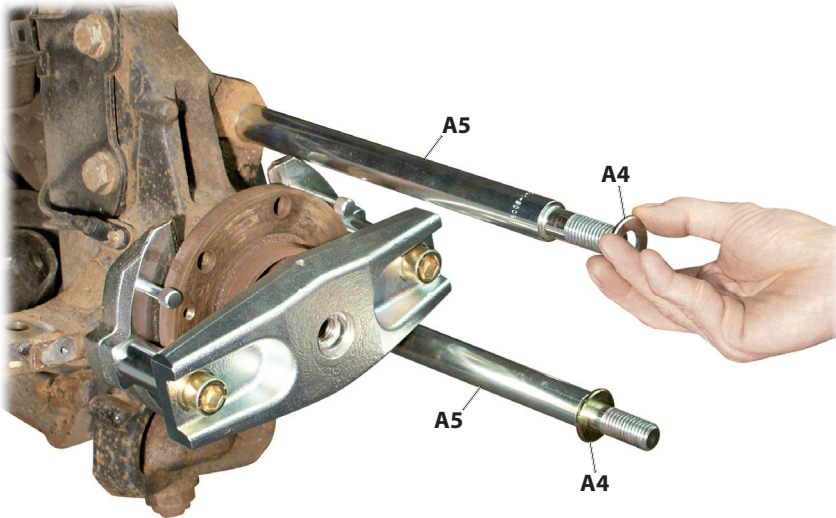

6. Place one washer [A4] on each of the support rods [A5].

EN

8: Place the base plate [A1] in the correct position on the support rods [A5] and secure...

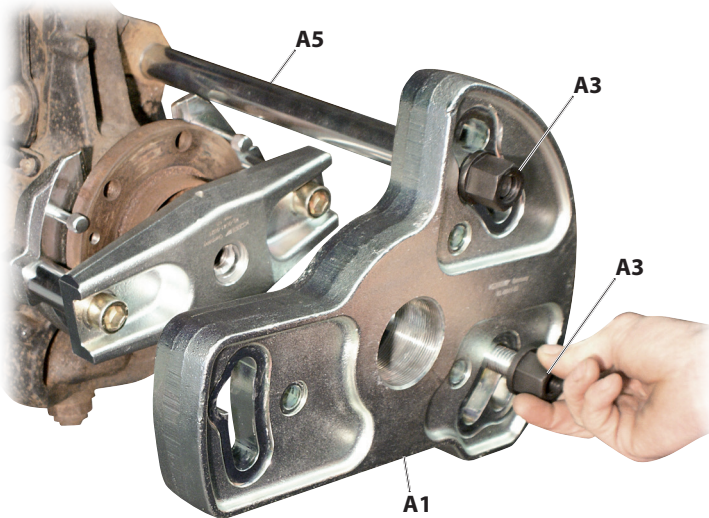

7. Place the base plate [A1] in the correct position on the support rods [A5] according to the **hole distance** of the base strip [E..] as shown.

Then screw both collar nuts [A3] onto the support rods [A5] lightly by hand.

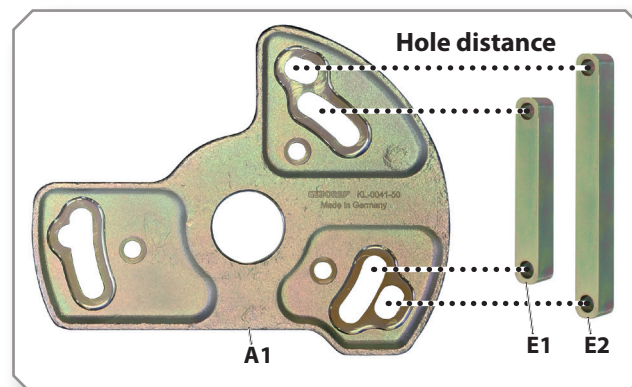

📸 9: Insert the support rod with cross hole [A6] on the steering knuckle and the base plate [A1] and secure...

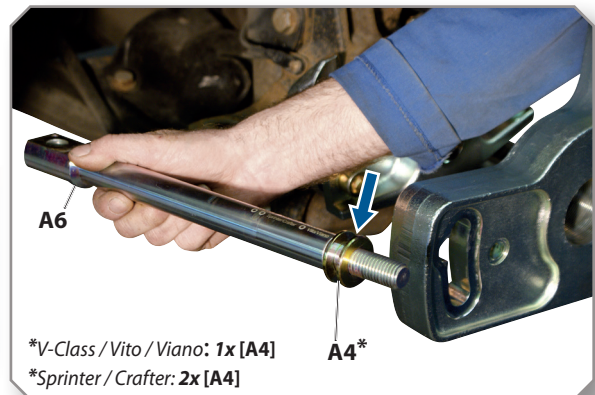
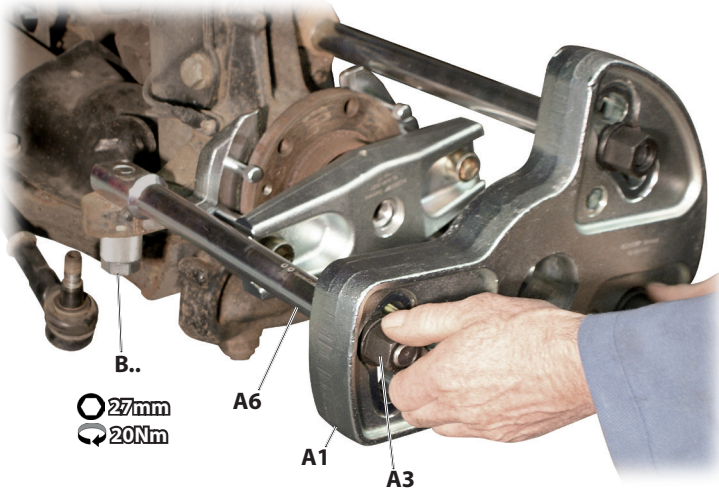

CAUTION

The wheel bearing tool can be damaged due to an inclined fit of the base plate [A1].

► For the Mercedes V-Class, Vito and Viano **one** washer [A4] **must** be placed on the support rod with cross hole [A6] and for Mercedes Sprinter and VW Crafter **two** washers [A4]!

8. Insert the support rod with cross hole [A6] as shown, in the correct position on the base plate [A1] and screw on the collar nut [A3] **slightly by hand**.

Then screw the support rod with cross hole [A6] on the steering knuckle by using the appropriate taper screw [B..] and tighten it with **20Nm**.

📸 10: Tighten the collar nuts [A3] uniformly and insert the steering knuckle retaining bracket [C]...

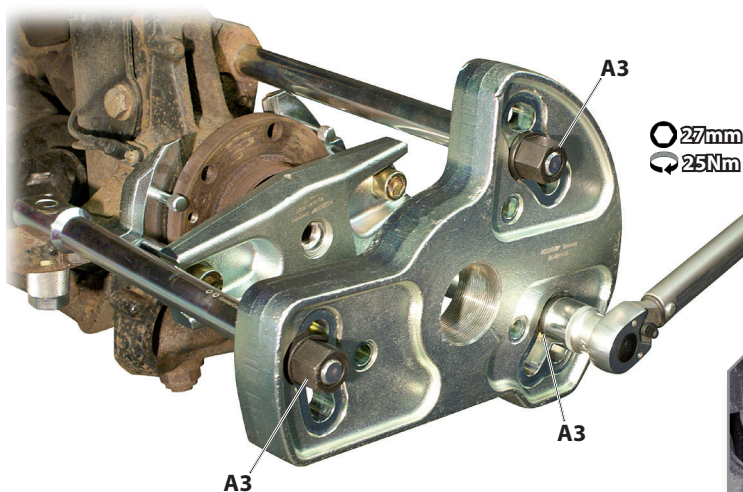

9. Tighten the **three** collar nuts [A3] uniformly to **25Nm**.

10. Insert the steering knuckle retaining bracket [C] as shown on the support rod with cross hole [A6] and the wishbone.

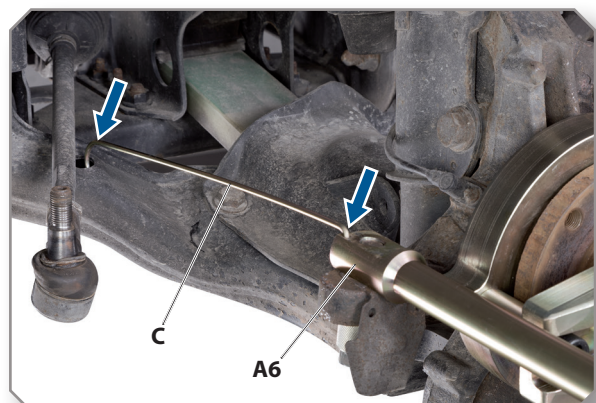

11: Prepare hydraulic cylinder [Z2] and screw at the base plate [A1]...

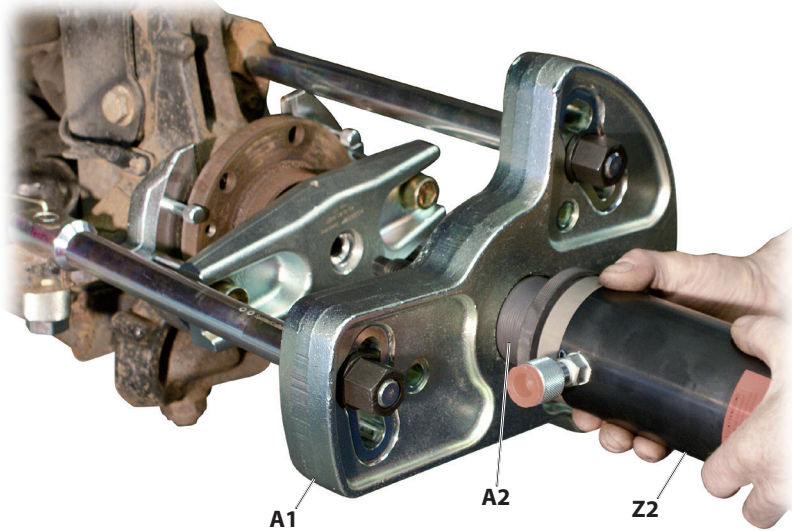

11. Prepare the hydraulic cylinder [Z2] accordingly as shown and subsequently screw it in with the **PULL SIDE** to the base plate [A1].

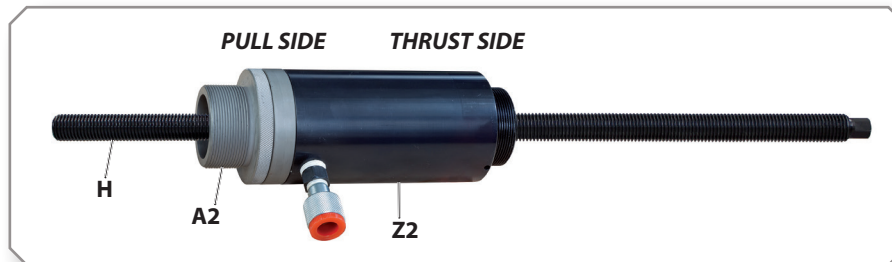

12: Screw in the pull spindle [H] completely on the bridge [F1]...

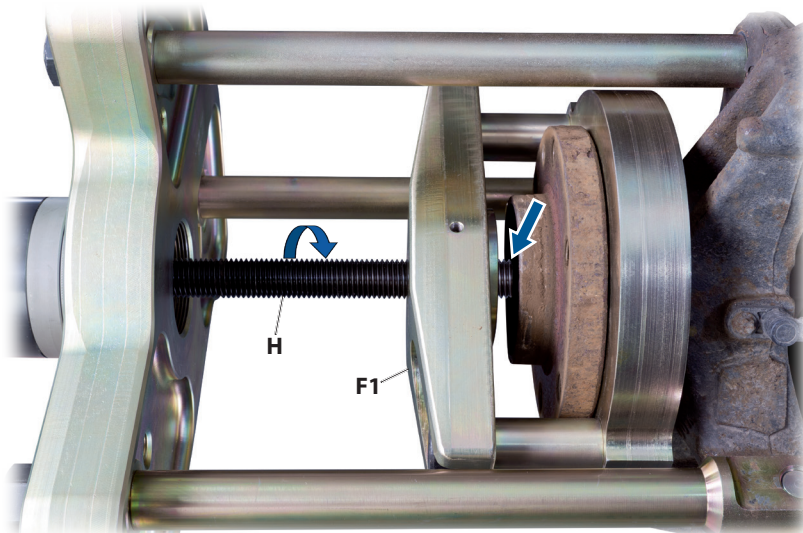

CAUTION

The pull spindle [H] can be torn out at the bridge [F1] and damaged.

► The pull spindle [H] **must** be screwed into the bridge [F1] until it protrudes at the back!

12. Screw the pull spindle [H] completely into the bridge [F1] as shown.

13: Pull out the wheel bearing unit in a controlled manner on the steering knuckle...

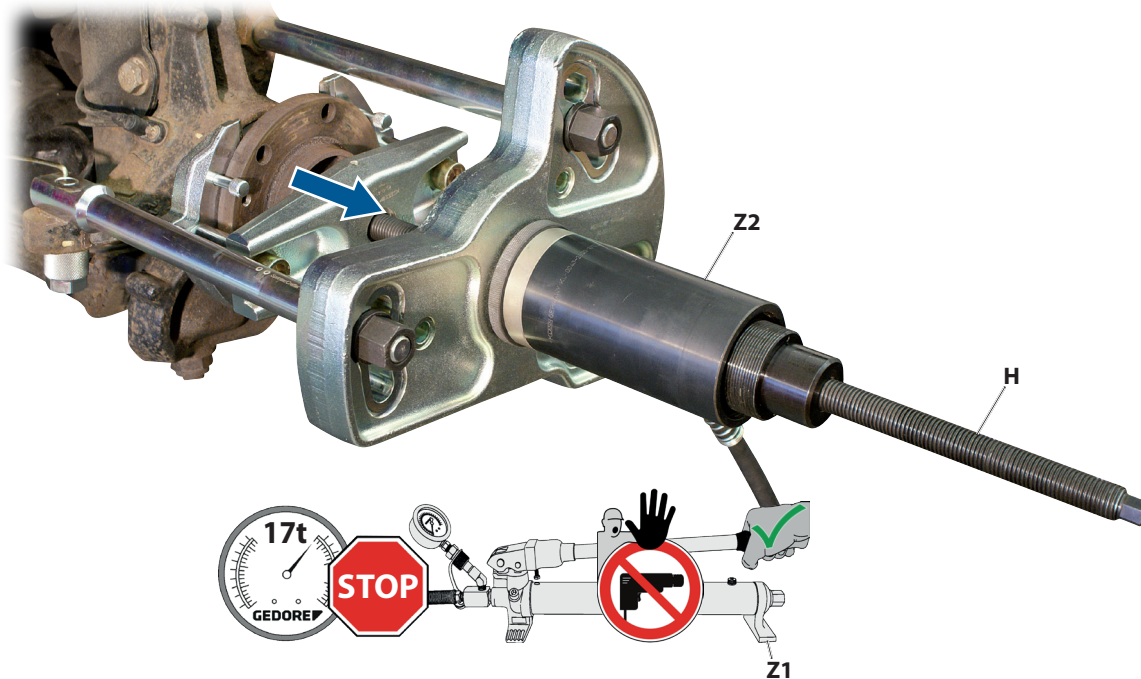

⚠ WARNING

The wheel bearing tool can break, fling around, and fall down when pulling out wheel bearing unit. This can cause **DEATH** or **SEVERE INJURIES!**

- ▀ The **max. load** of the wheel bearing tool of **17 tons** must **never be exceeded!**
- ▀ The pressure on the pressure gauge of the hydraulic pump [Z1] **must always** be observed during use!
- ▀ During use, **never** stand in axial extension of the loaded pull spindle [H]!
- ▀ The wheel bearing tool must **never** be used with a mechanical drive, e.g. an impulse or impact wrench or a drive other than that intended for it!
- ▀ The wheel bearing tool **must** be secured against flinging around and falling down, for example by holding it or via the safety retaining belt - **KL-0040-2590** or the support device - **KL-0040-258 A**

13. Connect the hydraulic pump [Z1] with the hydraulic cylinder [Z2]. Operate the hydraulic pump [Z1], observe the pressure on the pressure gauge and pull the wheel bearing unit out of the steering knuckle in a controlled manner.

① The maximum stroke of the hydraulic cylinder [Z2] is 45mm! As soon as it is reached: Interrupt the pressing process, release the pressure at the hydraulic pump [Z1], turn the pull spindle [H] again, continue the pressing process.

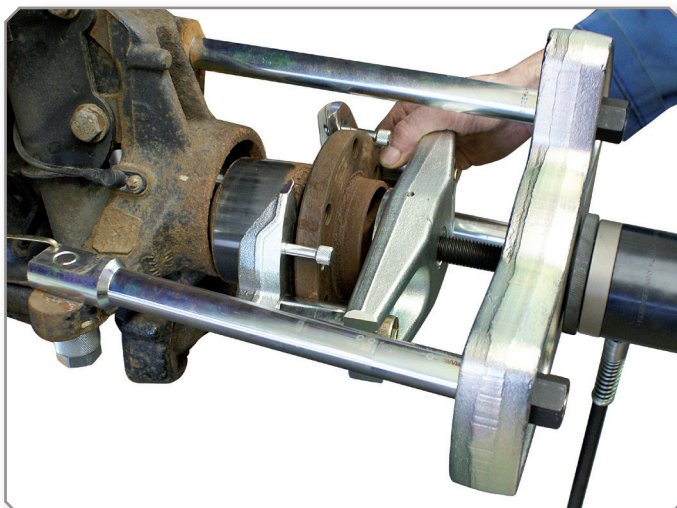

14. Remove the wheel bearing unit with bridge [F.] and tension/pressure plate [G.], and clean the wheel bearing bore on the steering knuckle.

4.2 Pressing in the wheel bearing unit on the front axle (rear drive)

📷 14: Insert the bridge [F..] with the tension/pressure plate [G..] in the correct position on the wheel bearing unit...

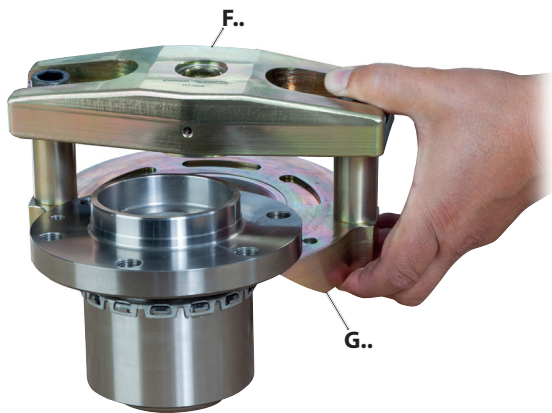

1. Place the bridge [F..] with the tension/pressure plate [G..] in the correct position on the new wheel bearing unit as shown.

CAUTION

The closing plate [G1.1] or [G2.1] and the wheel bearing unit may be damaged.

▼ The closing plate [G1.1] or [G2.1] **must** be inserted on the traction/pressure plate [G..] with the rounded side facing upwards towards the wheel hub!

2. Insert the locking plate [G1.1] or [G2.1] in the correct position on the corresponding tension/pressure plate [G..] as shown.



EN

📷 15: Secure bridge [F..] with tension/pressure plate [G..] and screw in knurled screws [F4] in the correct position...

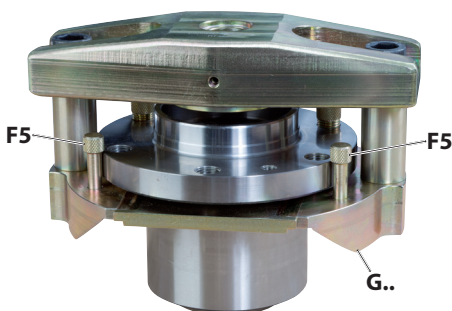

CAUTION

The wheel bearing unit may fall down during the assembly process and cause **INJURIES** to the feet.

▼ The wheel bearing unit **must** always be secured via both retaining pins [F5] at the tension / pressure plate [G..]!

3. To secure the wheel bearing unit, insert both retaining pins [F5] fully into the holes of the tension/pressure plate [G..] as shown.

4. Screw the three knurled screws [F4] into the wheel hub by hand as shown until they fit neatly in the groove on the tension/pressure plate [G..]. (see arrows).

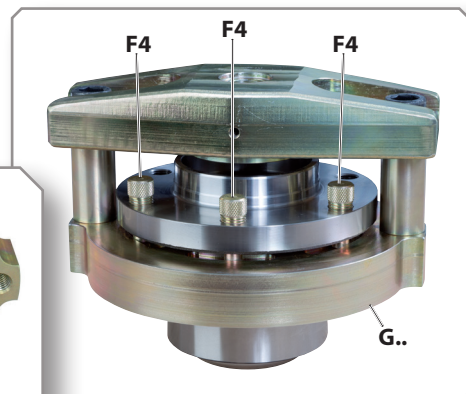
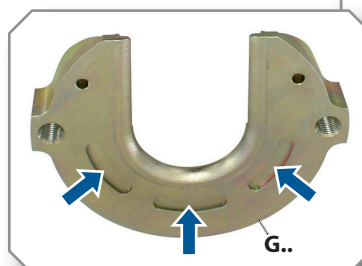

16: Prepare hydraulic cylinder [Z2] and screw at the base plate [A1]...

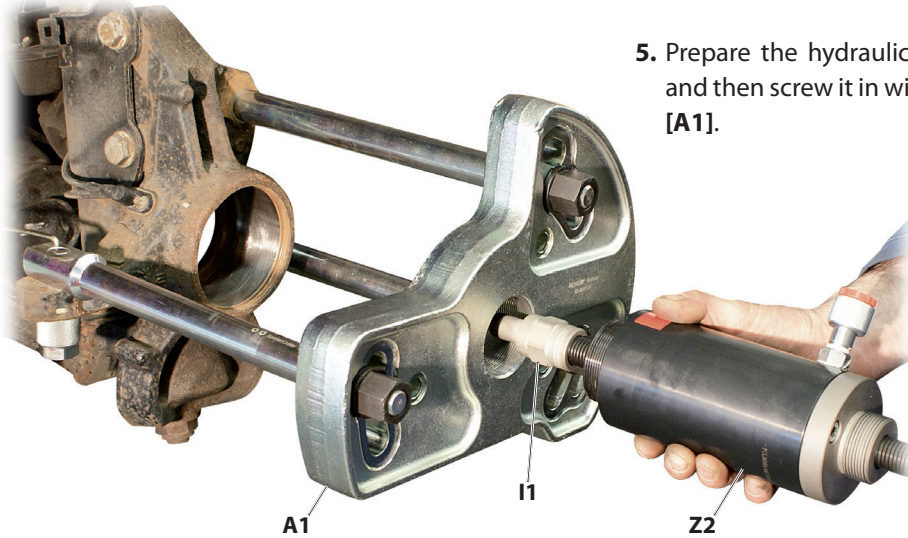

5. Prepare the hydraulic cylinder [Z2] accordingly as shown and then screw it in with the **THRUST SIDE** on the base plate [A1].

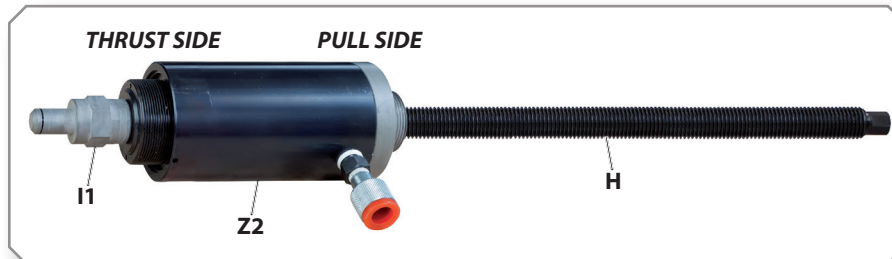

17: Insert bridge [F.] with tension/pressure plate [G..] and wheel bearing unit on the steering knuckle...

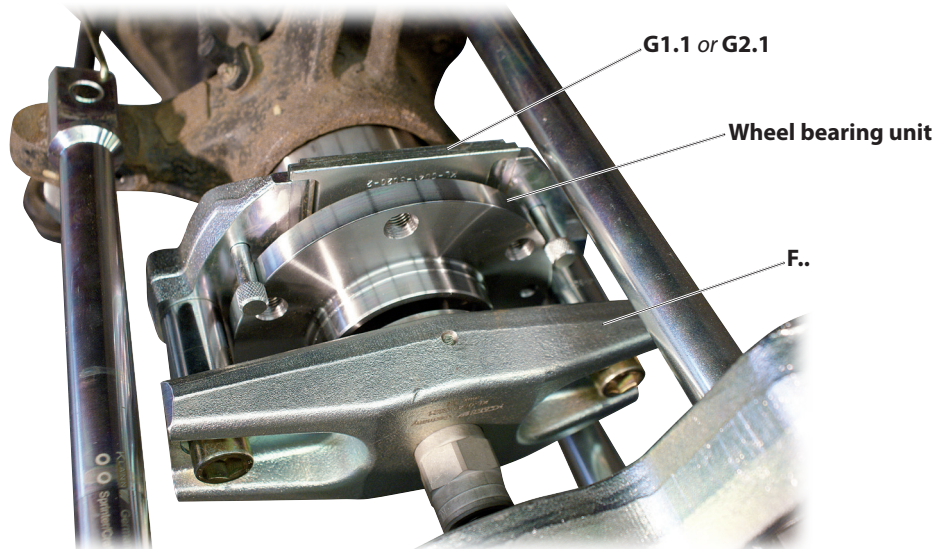

CAUTION

The closing plate [G1.1] or [G2.1] can fall down and cause **INJURY** to the feet.

► The bridge [F.] with tension/pressure plate [G..] **must** be inserted in such a way that the closing plate [G1.1] or [G2.1] points upwards!

6. Insert the bridge [F.] with the tension/pressure plate [G..] and the wheel bearing unit in the correct position on the steering knuckle as shown and turn the pull spindle [H] until the clamping nut [I1] is in contact.

📷 18: Press in the wheel bearing unit on the steering knuckle according to the manufacturer's specifications...

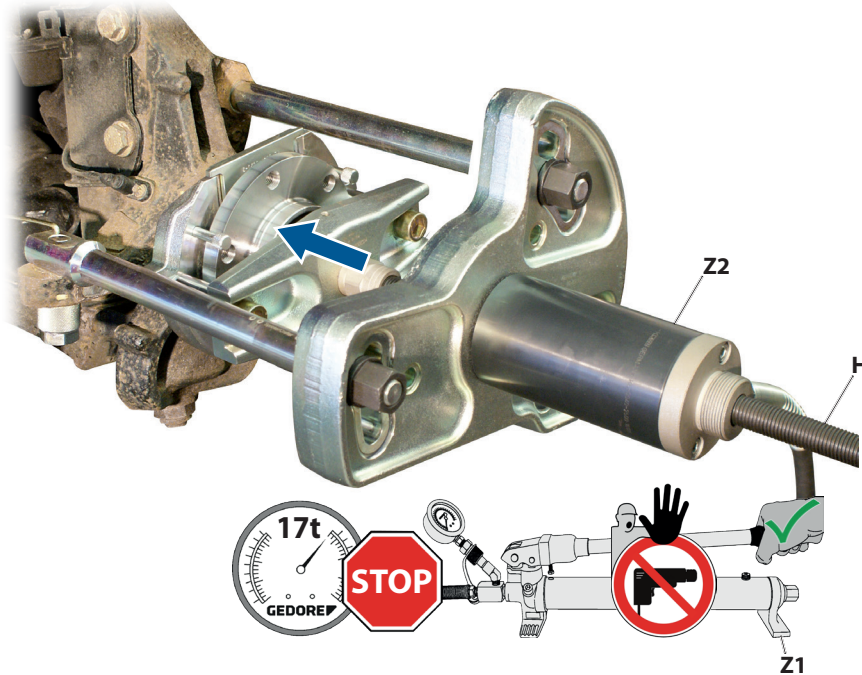

⚠️ WARNING

The wheel bearing tool can break, fling around, and fall down when pressing in the wheel bearing unit. This can cause **DEATH** or **SEVERE INJURIES!**

- The **max. load** of the wheel bearing tool of **17 tons** must **never be exceeded!**
- The pressure on the pressure gauge of the hydraulic pump [Z1] **must always** be observed during use!
- During use, **never** stand in axial extension of the loaded pull spindle [H]!
- The wheel bearing tool must **never** be used with a mechanical drive, e.g. an impulse or impact wrench or a drive other than that intended for it!
- The wheel bearing tool **must** be secured against flinging around and falling down, for example by holding it or via the safety retaining belt - **KL-0040-2590** or the support device - **KL-0040-258 A**

7. Connect the hydraulic pump [Z1] with the hydraulic cylinder [Z2]. Operate the hydraulic pump [Z1], observe the pressure on the pressure gauge and press the wheel bearing unit into the steering knuckle in the correct position according to the manufacturer's specifications.

ⓘ The maximum stroke of the hydraulic cylinder [Z2] is 45mm! As soon as it is reached: Interrupt the pressing process, release the pressure at the hydraulic pump [Z1], turn the pull spindle [H] again, continue the pressing process.



8. Check the correct installation position of the wheel bearing unit, remove the wheel bearing tool and reassemble the vehicle according to the manufacturer's specifications.

4.3 Pulling out the wheel hub and the wheel bearing on the front axle (front-wheel/all-wheel drive)

📷 19: Mount the support rods [A5] with washers [A4] and the reinforcement bar [E..] in the correct position on the steering knuckle...

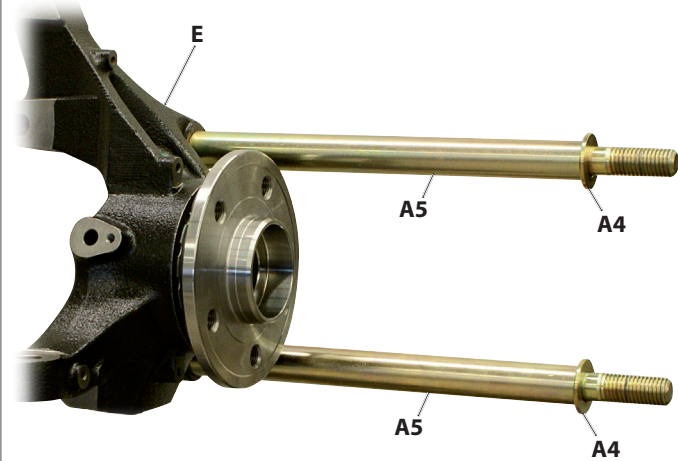

1. Choose the reinforcement bar [E1] or [E2] depending on the hole distance on the steering knuckle.

Screw the reinforcement bar [E..] together with both support rods [A5] as shown on the steering knuckle and tighten the screws [D] with 25Nm.

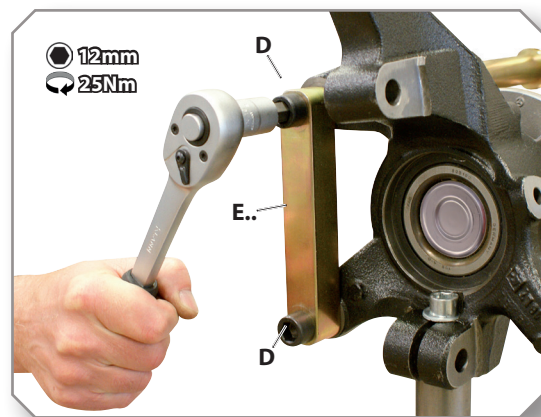

2. Then place one washer [A4] on each of the support rods [A5].

📷 20: Place the base plate [A1] in the correct position on the support rods [A5] and secure...

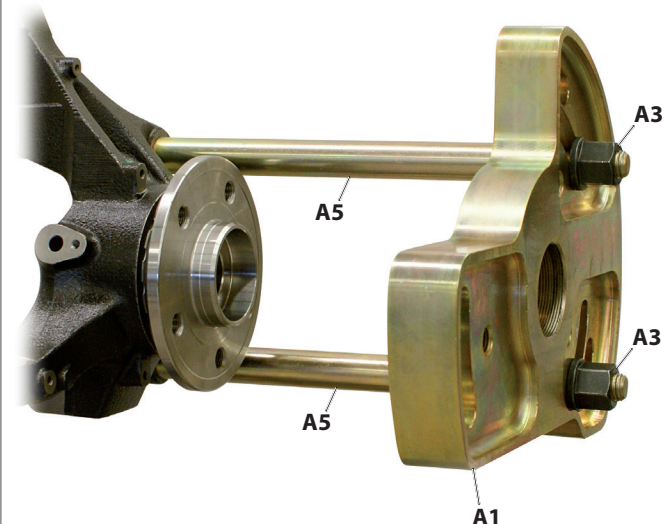

3. Place the base plate [A1] in the correct position on the support rods [A5] according to the **hole distance** of the base strip [E..] as shown.

Then screw both collar nuts [A3] onto the support rods [A5] lightly by hand.

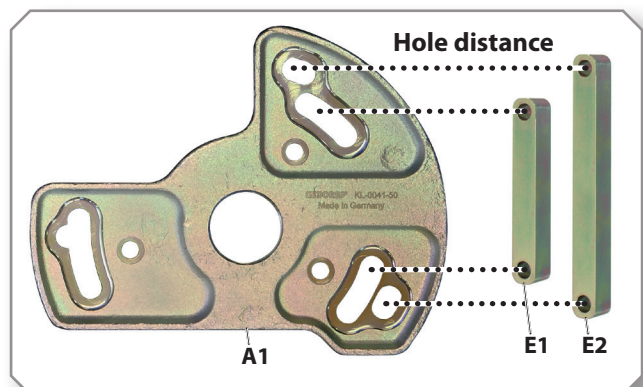

📷 21: Insert the support rod with cross hole [A6] on the steering knuckle and the base plate [A1] and secure...

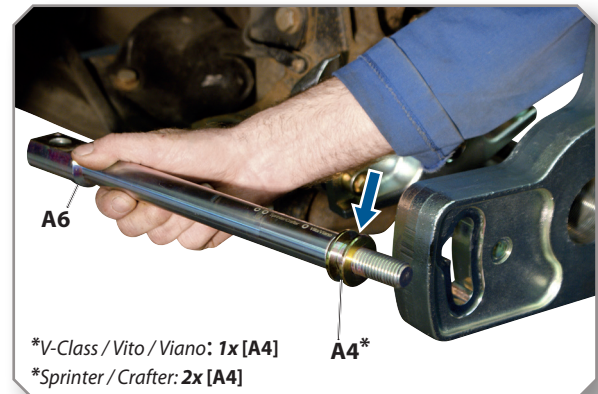
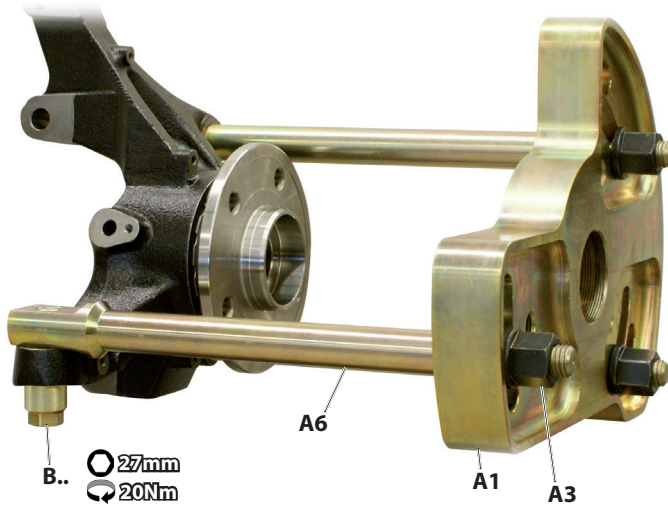

CAUTION

The wheel bearing tool can be damaged due to an inclined fit of the base plate [A1].

► For the Mercedes V-Class, Vito and Viano **one** washer [A4] **must** be placed on the support rod with cross hole [A6] and for Mercedes Sprinter and VW Crafter **two** washers [A4]!

4. Insert the support rod with cross hole [A6] as shown, in the correct position on the base plate [A1] and screw on the collar nut [A3] slightly by hand.

Then screw the support rod with cross hole [A6] on the steering knuckle by using the appropriate taper screw [B..] and tighten it with **20Nm**.

📷 22: Tighten the collar nuts [A3] uniformly and insert the steering knuckle retaining bracket [C]...

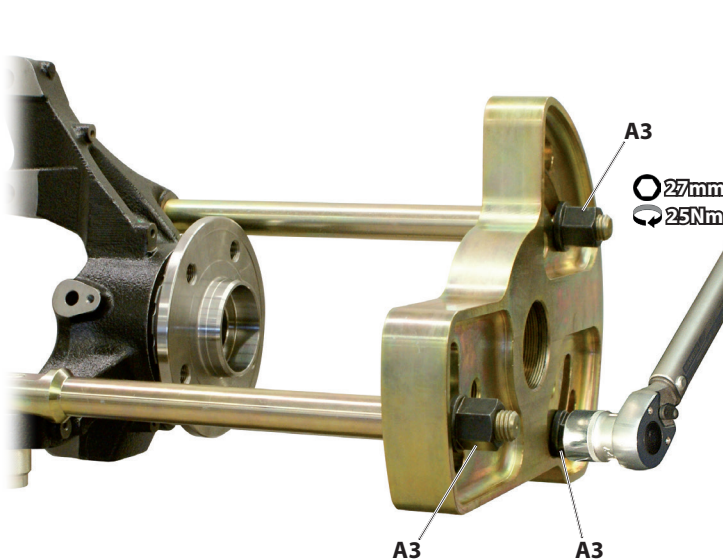

5. Tighten the three collar nuts [A3] uniformly to **25Nm**.

6. Insert the steering knuckle retaining bracket [C] as shown on the support rod with cross hole [A6] and the wishbone.

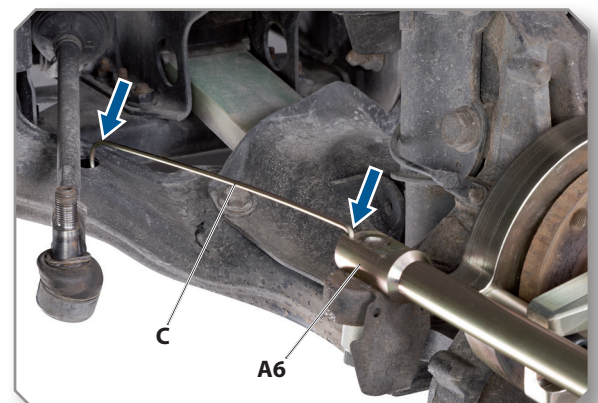

📷 23: Prepare hydraulic cylinder [Z2] accordingly and screw at the base plate [A1]...

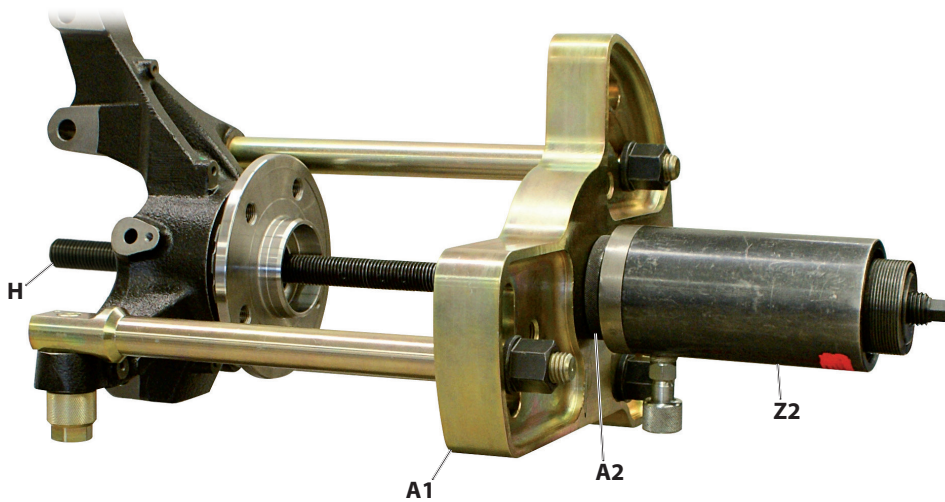

7. Prepare the hydraulic cylinder [Z2] accordingly as shown and subsequently screw it in with the **PULL SIDE** to the base plate [A1].

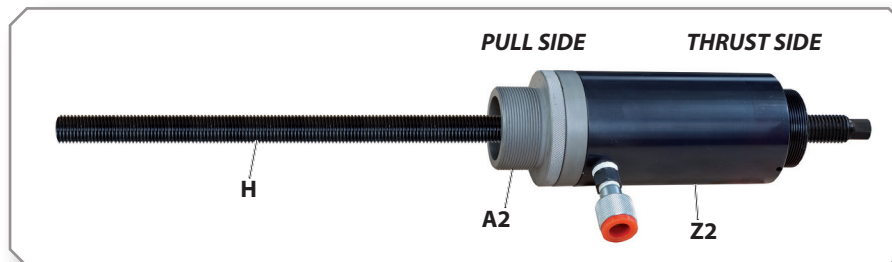

📷 24: Screw the clamping nut [K] onto the pull spindle [H] in the correct position...

ⓘ If the wheel hub is not to be used again later, you can simply skip this step and continue with 📷 26 / step 10.

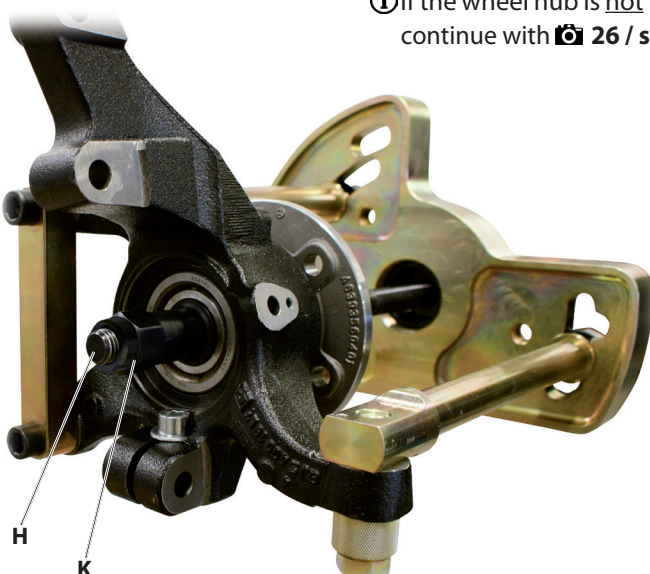

CAUTION

The pull spindle [H] can be torn out and damaged at the clamping nut [K].

➤ The clamping nut [K] **must** be screwed onto the pull spindle [H] until the thread protrudes at the back!

8. Screw the clamping nut [K] as shown, with the **conical side** in the correct position, onto the pull spindle [H].

25: Pulling out the wheel hub on the wheel bearing in a controlled manner...

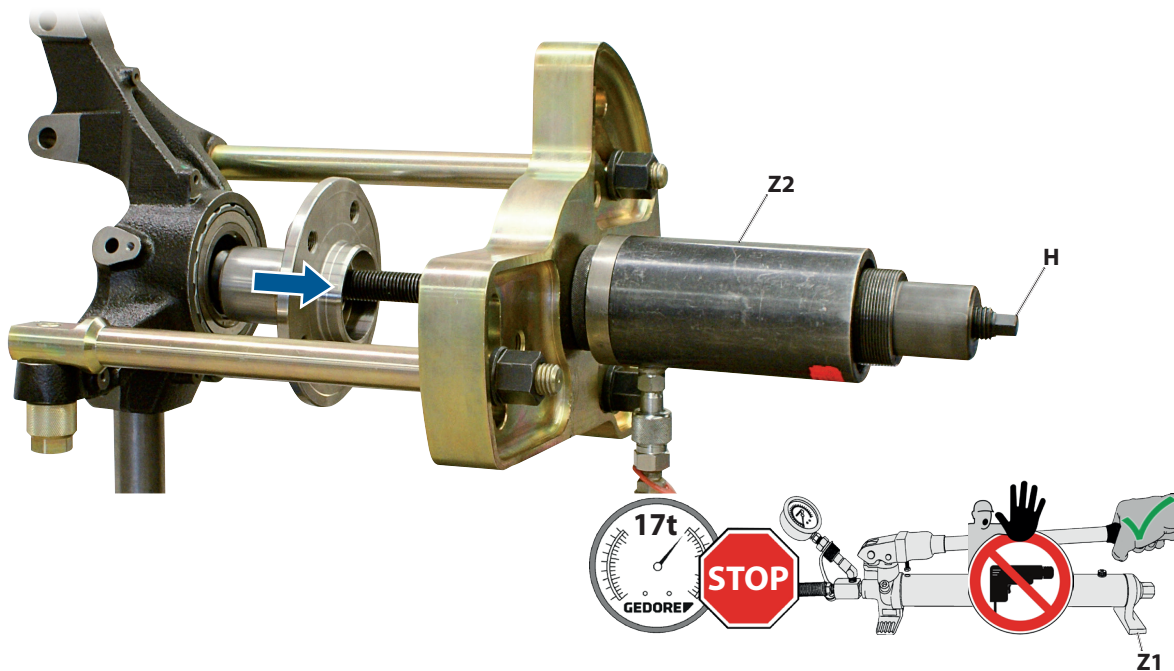

!WARNING

The wheel bearing tool can break, fling around, and fall down when pulling out wheel hub. This can cause **DEATH** or **SEVERE INJURIES!**

- ▀ The **max. load** of the wheel bearing tool of **17 tons** must **never be exceeded!**
- ▀ The pressure on the pressure gauge of the hydraulic pump [Z1] **must always** be observed during use!
- ▀ During use, **never** stand in axial extension of the loaded pull spindle [H]!
- ▀ The wheel bearing tool must **never** be used with a mechanical drive, e.g. an impulse or impact wrench or a drive other than that intended for it!
- ▀ The wheel bearing tool **must** be secured against flinging around and falling down, for example by holding it or via the safety retaining belt - **KL-0040-2590** or the support device - **KL-0040-258 A**

9. Connect the hydraulic pump [Z1] with the hydraulic cylinder [Z2]. Operate the hydraulic pump [Z1], observe the pressure on the pressure gauge and pull the wheel hub out of the wheel bearing in a controlled manner.

i The maximum stroke of the hydraulic cylinder [Z2] is 45mm! As soon as it is reached: Interrupt the pressing process, release the pressure at the hydraulic pump [Z1], turn the pull spindle [K] again, continue the pressing process.



i If the wheel hub is to be used again, the wheel bearing inner ring must be removed first. For example, with the help of the **puller kit for bearing inner rings - KL-0042-90 K**, which is available as an *accessory*

KL-0042-90 K (accessory)

26: Prepare hydraulic cylinder [Z2] accordingly and screw at the base plate [A1]...

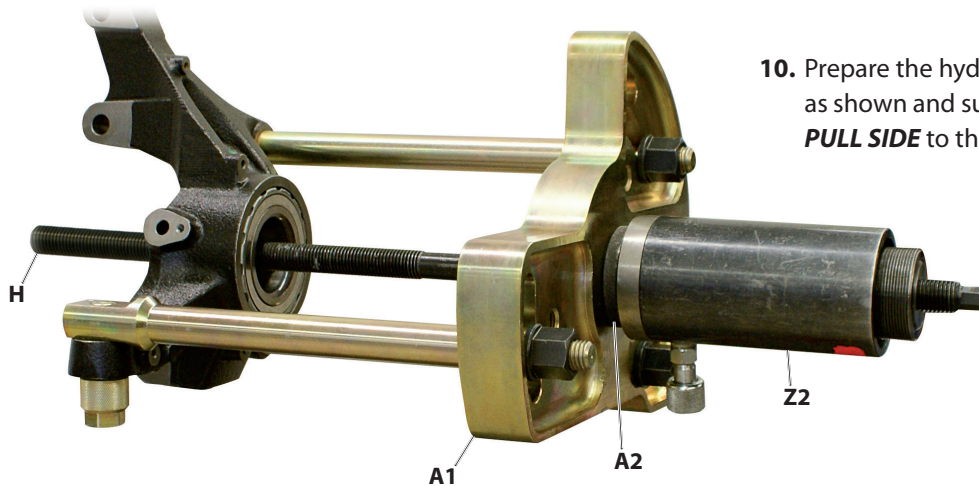

10. Prepare the hydraulic cylinder [Z2] accordingly as shown and subsequently screw it in with the **PULL SIDE** to the base plate [A1].

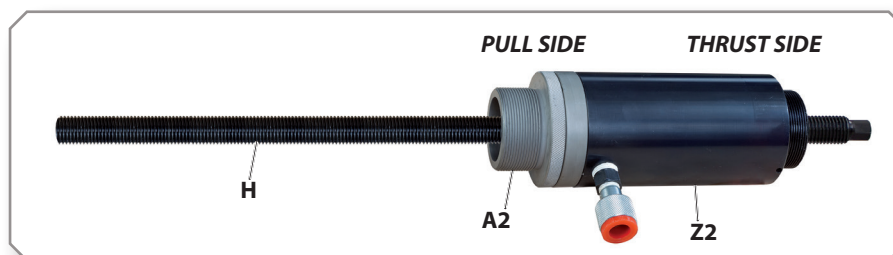

27: Screw the clamping nut [K] onto the pull spindle [H] in the correct position...

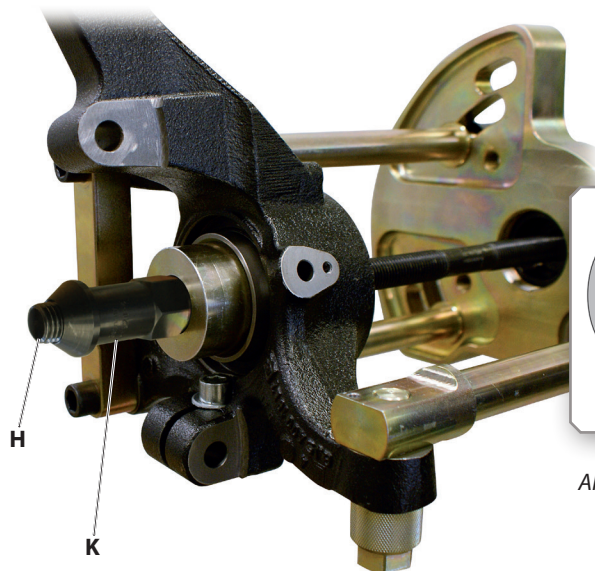

11. Depending on the wheel bearing \emptyset , select a suitable centring ring [O..] which fits exactly into the inner \emptyset of the wheel bearing and a suitable thrust ring [P..] which fits exactly onto the inner ring on the wheel bearing.

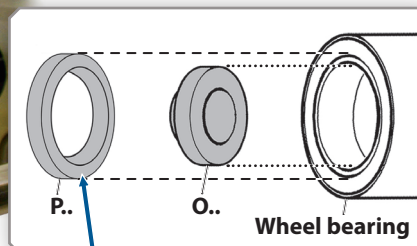

Align towards the flat side!

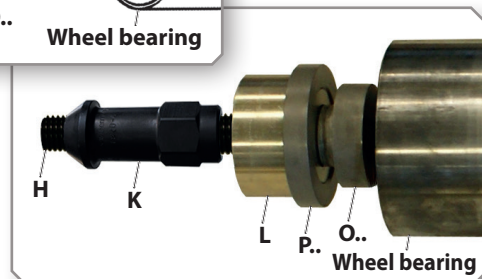

CAUTION

The pull spindle [H] can be torn out and damaged at the clamping nut [K].

►The clamping nut [K] **must** be screwed onto the pull spindle [H] until the thread protrudes at the back!

12. Place the mounting adapter [L] together with the matching thrust ring [P..] and centring ring [O..] in the correct position on the pull spindle [H] as shown. Then screw the clamping nut [K] with the **flat side** in the correct position onto the pull spindle [H].

28: Pull out the wheel bearing in a controlled manner on the steering knuckle...

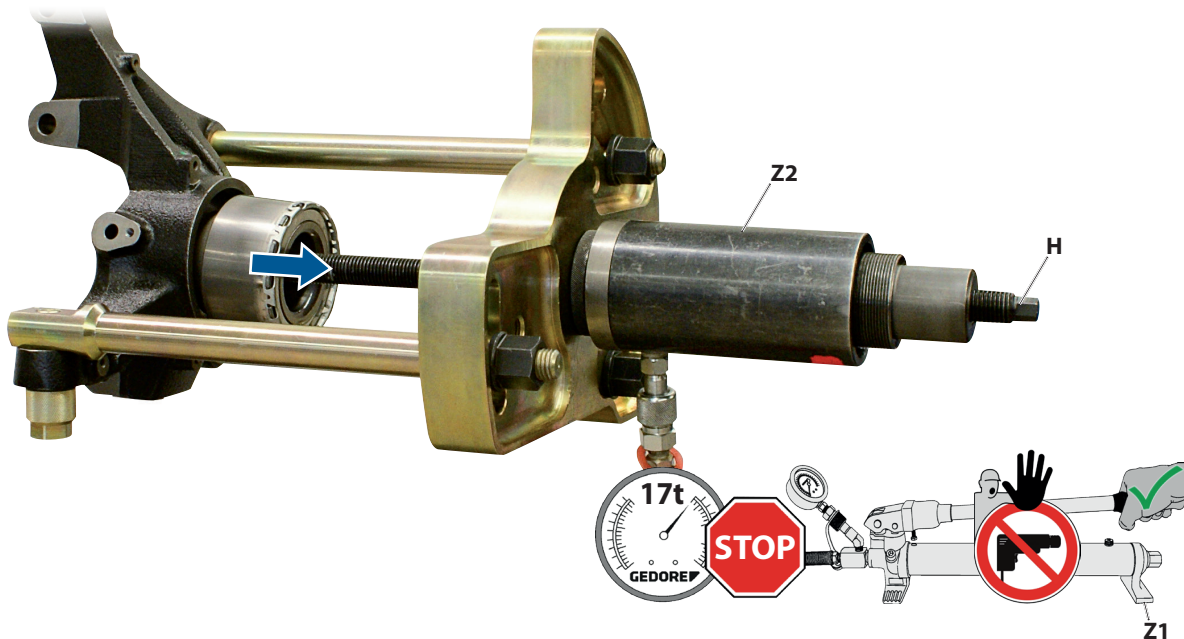

!WARNING

The wheel bearing tool can break, fling around, and fall down when pulling out wheel bearing. This can cause **DEATH** or **SEVERE INJURIES!**

- ▀ The **max. load** of the wheel bearing tool of **17 tons** must **never be exceeded!**
- ▀ The pressure on the pressure gauge of the hydraulic pump [Z1] **must always** be observed during use!
- ▀ During use, **never** stand in axial extension of the loaded pull spindle [H]!
- ▀ The wheel bearing tool must **never** be used with a mechanical drive, e.g. an impulse or impact wrench or a drive other than that intended for it!
- ▀ The wheel bearing tool **must** be secured against flinging around and falling down, for example by holding it or via the safety retaining belt - **KL-0040-2590** or the support device - **KL-0040-258 A**

13. Connect the hydraulic pump [Z1] with the hydraulic cylinder [Z2]. Operate the hydraulic pump [Z1], observe the pressure on the pressure gauge and pull the wheel bearing out of the steering knuckle in a controlled manner.

i The maximum stroke of the hydraulic cylinder [Z2] is 45mm! As soon as it is reached: Interrupt the pressing process, release the pressure at the hydraulic pump [Z1], turn the pull spindle [K] again, continue the pressing process.



14. Remove the wheel bearing unit with bridge [F.] and tension/pressure plate [G.]. and clean the wheel bearing bore on the steering knuckle.

4.4 Pressing in the wheel bearing and the wheel hub on the front axle (front-wheel/all-wheel drive)

29: Prepare hydraulic cylinder [Z2] and screw at the base plate [A1]...

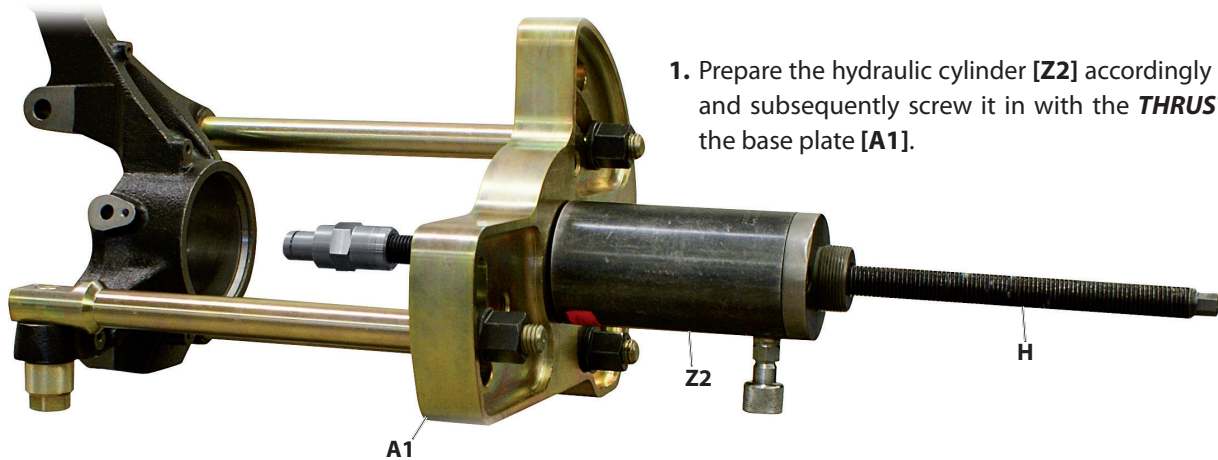

1. Prepare the hydraulic cylinder [Z2] accordingly as shown and subsequently screw it in with the **THRUST SIDE** to the base plate [A1].

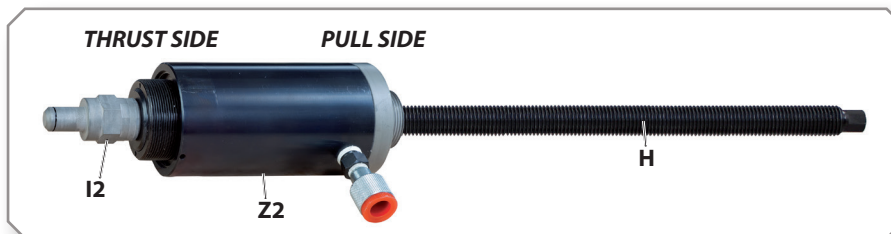

30: Place the wheel bearing on the clamping nut [I2]...

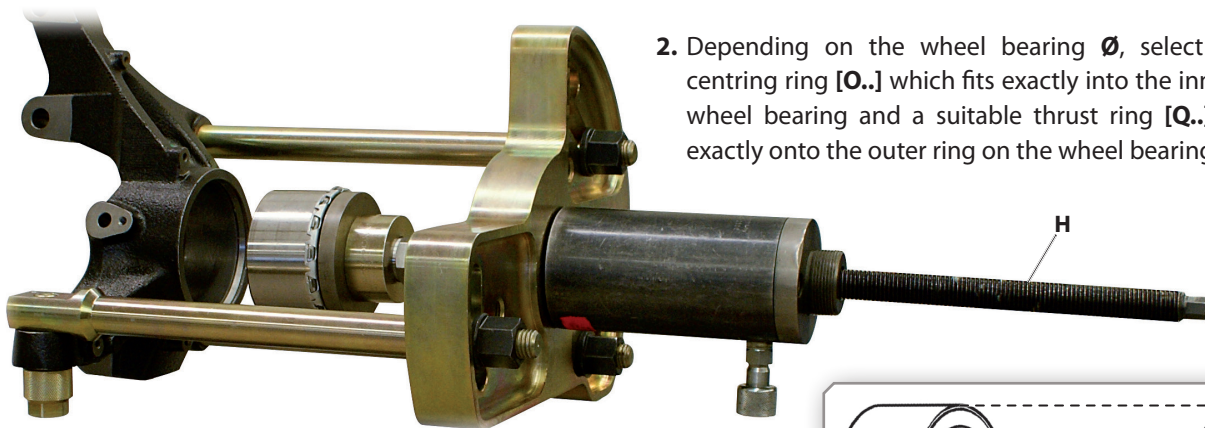

2. Depending on the wheel bearing \varnothing , select a suitable centring ring [O..] which fits exactly into the inner \varnothing of the wheel bearing and a suitable thrust ring [Q..] which fits exactly onto the outer ring on the wheel bearing.

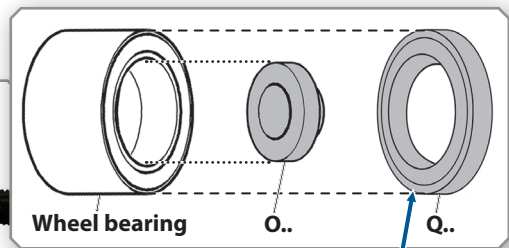
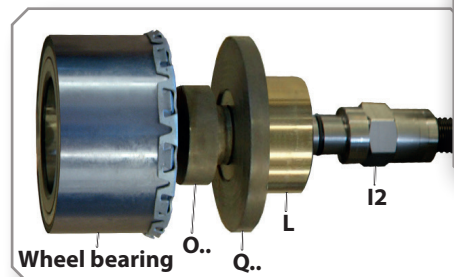

Align towards the offset side!

3. Place the mounting adapter [L] together with the matching centring ring [O..], thrust ring [Q..] and wheel bearing in the correct position on the clamping nut [I2] as shown. Then screw in the pull spindle [H] until the wheel bearing is in contact with the steering knuckle.

31: Press in the wheel bearing on the steering knuckle in the correct position according to the manufacturer's specifications...

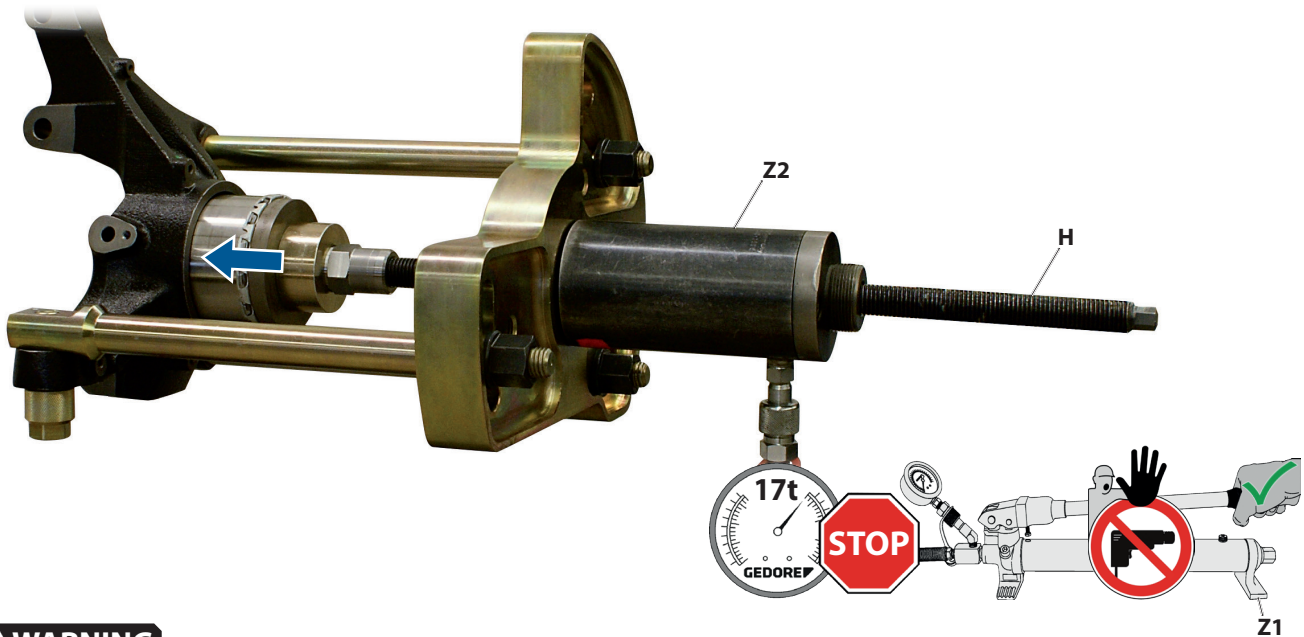

WARNING

The wheel bearing tool can break, fling around, and fall down when pressing in the wheel bearing. This can cause **DEATH** or **SEVERE INJURIES!**

- ▀ The **max. load** of the wheel bearing tool of **17 tons** must **never be exceeded!**
 - ▀ The pressure on the pressure gauge of the hydraulic pump [Z1] **must always** be observed during use!
 - ▀ During use, **never** stand in axial extension of the loaded pull spindle [H]!
 - ▀ The wheel bearing tool must **never** be used with a mechanical drive, e.g. an impulse or impact wrench or a drive other than that intended for it!
 - ▀ The wheel bearing tool **must** be secured against flinging around and falling down, for example by holding it or via the safety retaining belt - **KL-0040-2590** or the support device - **KL-0040-258 A**
4. Connect the hydraulic pump [Z1] with the hydraulic cylinder [Z2]. Operate the hydraulic pump [Z1], observe the pressure on the pressure gauge and press the wheel bearing into the steering knuckle in the correct position according to the manufacturer's specifications.

① The maximum stroke of the hydraulic cylinder [Z2] is 45mm! As soon as it is reached: Interrupt the pressing process, release the pressure at the hydraulic pump [Z1], turn the pull spindle [H] again, continue the pressing process.



5. Check the correct installation position of the wheel bearing according to the manufacturer's specifications, remove the wheel bearing tool and, if necessary, insert the wheel bearing retaining ring on the steering knuckle.

32: Prepare hydraulic cylinder [Z2] and attach to steering knuckle and secure....

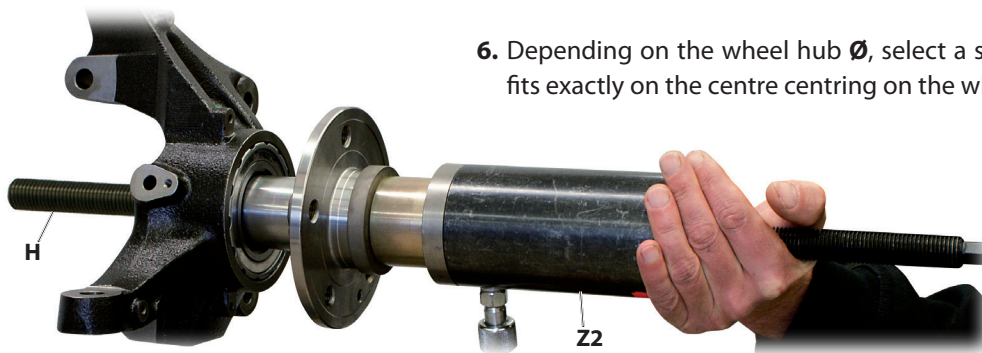

6. Depending on the wheel hub \varnothing , select a suitable thrust ring [P.], which fits exactly on the centre centring on the wheel hub.

7. Prepare the hydraulic cylinder [Z2] accordingly as shown and insert it with the **PULL SIDE** on the wheel bearing.

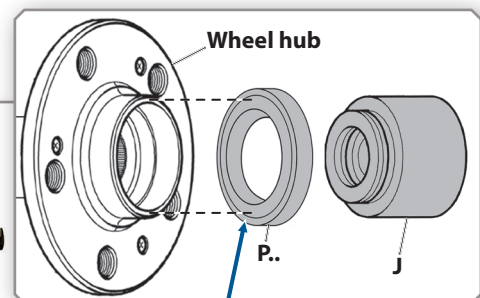
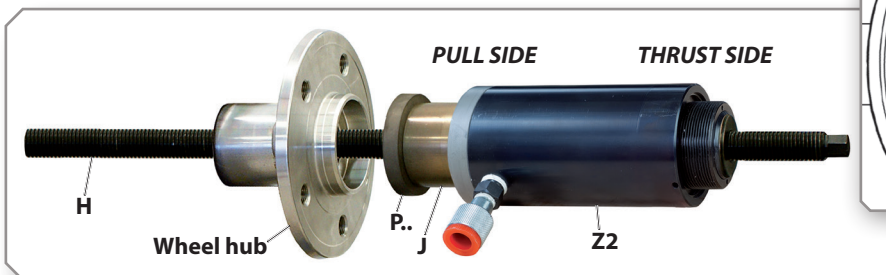

Align towards the offset side!

33: Screw the clamping nut [K] onto the pull spindle [H] in the correct position...

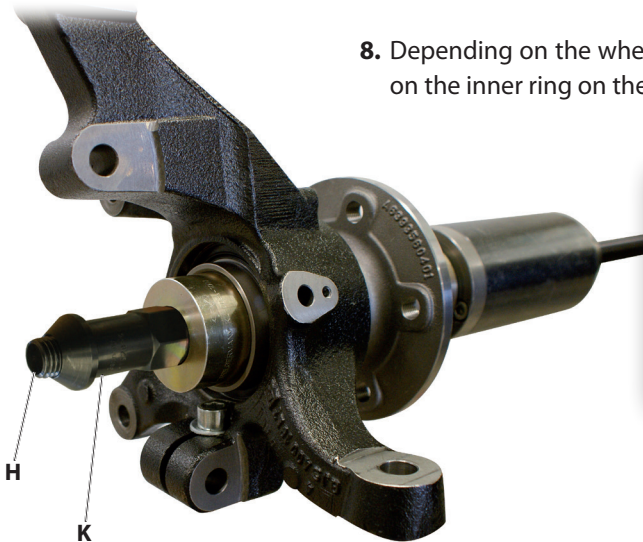

8. Depending on the wheel bearing \varnothing , select a suitable thrust ring [P.] which fits exactly on the inner ring on the wheel bearing.

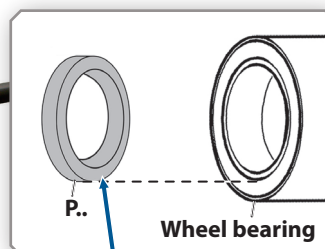

Align towards the flat side!

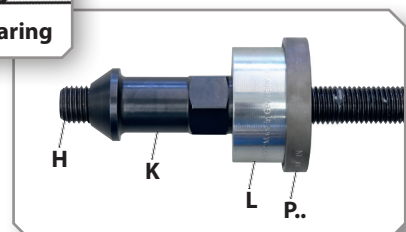

CAUTION

The pull spindle [H] can be torn out and damaged at the clamping nut [K].

► The clamping nut [K] **must** be screwed onto the pull spindle [H] until the thread protrudes at the back!

9. Place the adapter [L] together with the matching thrust ring [P.] in the correct position on the pull spindle [H] as shown. Then screw the clamping nut [K] with the flat side in the correct position onto the pull spindle [H].

34: Force in the wheel hub into the wheel bearing in the correct position according to manufacturer's specifications.

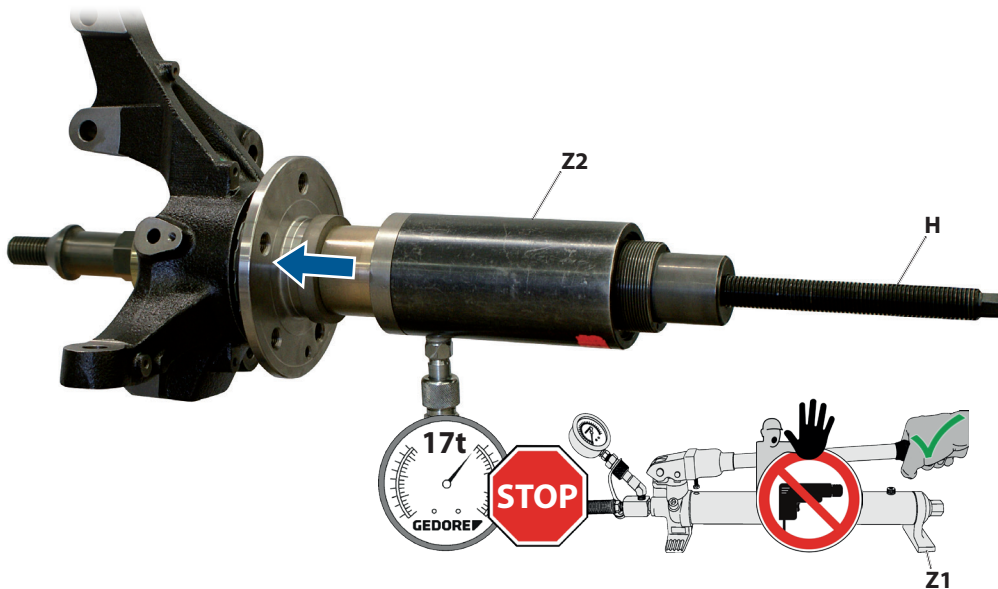

⚠ WARNING

The wheel bearing tool can break, fling around, and fall down when pressing in the wheel hub. This can cause **DEATH** or **SEVERE INJURIES!**

- ▣ The **max. load** of the wheel bearing tool of **17 tons** must **never be exceeded!**
- ▣ The pressure on the pressure gauge of the hydraulic pump **[Z1]** **must always** be observed during use!
- ▣ During use, **never** stand in axial extension of the loaded pull spindle **[H]!**
- ▣ The wheel bearing tool must **never** be used with a mechanical drive, e.g. an impulse or impact wrench or a drive other than that intended for it!
- ▣ The wheel bearing tool **must** be secured against flinging around and falling down, for example by holding it or via the safety retaining belt - **KL-0040-2590** or the support device - **KL-0040-258 A**

10. Connect the hydraulic pump **[Z1]** with the hydraulic cylinder **[Z2]**. Operate the hydraulic pump **[Z1]**, observe the pressure on the pressure gauge and press the wheel hub into the wheel bearing in the correct position according to the manufacturer's specifications.

ⓘ The maximum stroke of the hydraulic cylinder **[Z2]** is 45mm! As soon as it is reached: Interrupt the pressing process, release the pressure at the hydraulic pump **[Z1]**, turn the pull spindle **[K]** again, continue the pressing process.



11. Check the correct installation position of the wheel hub, remove the wheel bearing tool and reassemble the vehicle according to the manufacturer's specifications.

4.5 Pulling out the wheel hub and the wheel bearing on the rear axle (front-wheel/all-wheel drive)

35: Pull out the wheel hub, for example, using the KL-0174-.. -Puller series (accessory)...

① First, the wheel hub must be pulled out at the wheel bearing, for example using the **KL-0174-.. - Puller series** available as an **accessory** or the **wheel hub extractor - KL-0041-3800 A**.



1A. Pull out the wheel hub as shown, using the **KL-0174-.. Puller series** available as an **accessory**. Always follow the corresponding instructions.



36: Pull out the wheel hub, for example, using the KL-0041-3800 A - Wheel hub extractor (accessory)...

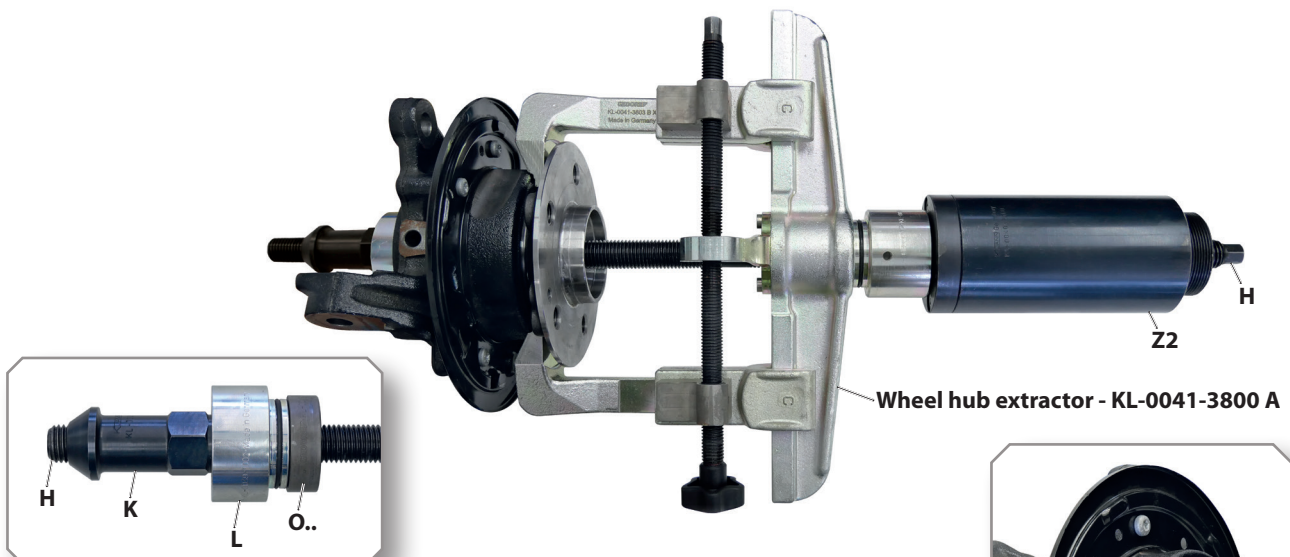

1B. Pull out the wheel hub as shown using the **KL-0041-3800 A - Wheel hub extractor** available as an **accessory**. Always follow the corresponding instructions.

① The wheel bearing can also be pulled out in the same way with the **wheel hub extractor**.



37: Prepare hydraulic cylinder [Z2] and attach to steering knuckle and secure...

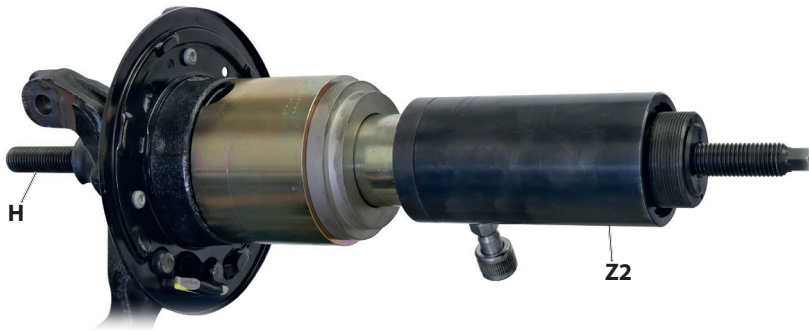

2. Prepare the hydraulic cylinder [Z2] accordingly as shown and insert it with the **PULL SIDE** on the wheel bearing.

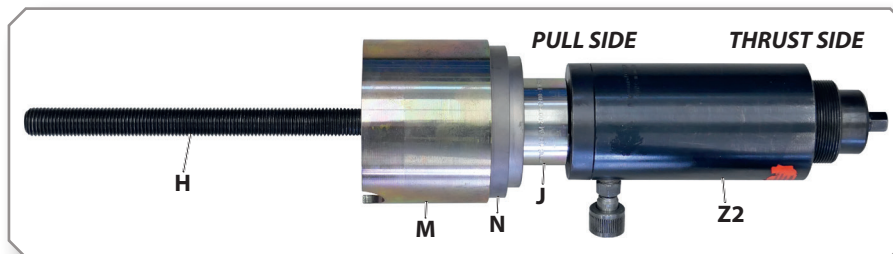

38: Screw the clamping nut [K] onto the pull spindle [H] in the correct position...

3. Depending on the wheel bearing \emptyset , select a suitable centring ring [O.] which fits exactly into the inner \emptyset of the wheel bearing and a suitable thrust ring [P.] which fits exactly onto the inner ring on the wheel bearing.

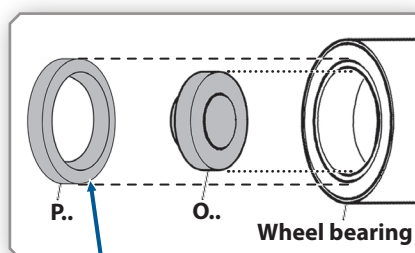
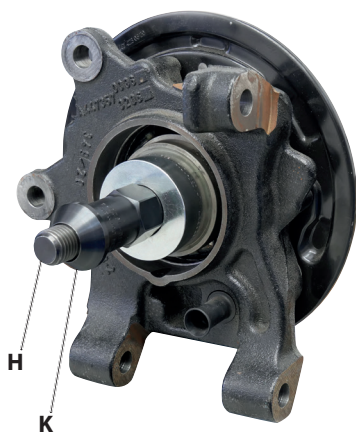

Align towards the flat side!

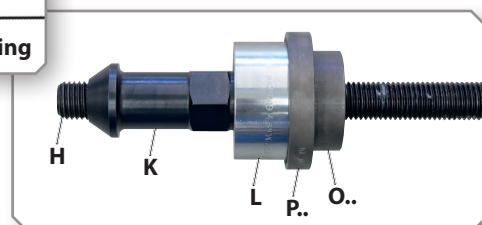

CAUTION

The pull spindle [H] can be torn out and damaged at the clamping nut [K].

► The clamping nut [K] **must** be screwed onto the pull spindle [H] until the thread protrudes at the back!

4. Place the mounting adapter [L] together with the matching thrust ring [P.] and centring ring [O.] in the correct position on the pull spindle [H] as shown. Then screw the clamping nut [K] with the **flat side** in the correct position onto the pull spindle [H].

39: Pull out the wheel bearing in a controlled manner on the steering knuckle...

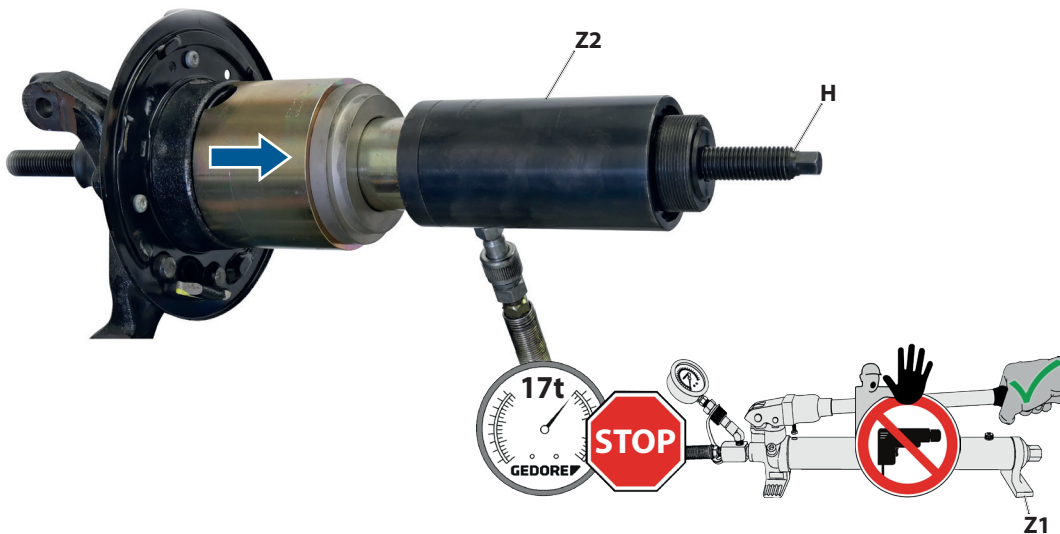

⚠ WARNING

The wheel bearing tool can break, fling around, and fall down when pulling out wheel bearing. This can cause **DEATH** or **SEVERE INJURIES!**

- ▣ The **max. load** of the wheel bearing tool of **17 tons** must **never be exceeded!**
- ▣ The pressure on the pressure gauge of the hydraulic pump [Z1] **must always** be observed during use!
- ▣ During use, **never** stand in axial extension of the loaded pull spindle [H]!
- ▣ The wheel bearing tool must **never** be used with a mechanical drive, e.g. an impulse or impact wrench or a drive other than that intended for it!
- ▣ The wheel bearing tool **must** be secured against flinging around and falling down, for example by holding it or via the safety retaining belt - **KL-0040-2590** or the support device - **KL-0040-258 A**

9. Connect the hydraulic pump [Z1] with the hydraulic cylinder [Z2]. Operate the hydraulic pump [Z1], observe the pressure on the pressure gauge and pull the wheel bearing out of the steering knuckle in a controlled manner.

ⓘ The maximum stroke of the hydraulic cylinder [Z2] is 45mm! As soon as it is reached: Interrupt the pressing process, release the pressure at the hydraulic pump [Z1], turn the pull spindle [K] again, continue the pressing process.



ⓘ If the wheel hub is to be used again, the wheel bearing inner ring must be removed first. For example, with the help of the **puller kit for bearing inner rings - KL-0042-90 K**, which is available as an *accessory*

KL-0042-90 K (accessory)

**4.6 Pressing in the wheel bearing and the wheel hub on the rear axle
(front-wheel/all-wheel drive)**

📷 40: Prepare hydraulic cylinder [Z2] and attach to steering knuckle and secure...

1. Depending on the wheel bearing \varnothing , select a suitable centring ring [O..] which fits exactly into the inner \varnothing of the wheel bearing and a suitable thrust ring [Q..] which fits exactly onto the outer ring on the wheel bearing.

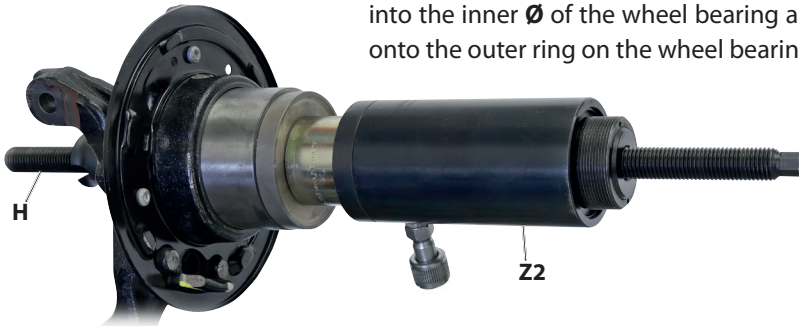

2. Prepare the hydraulic cylinder [Z2] accordingly as shown and then insert it with the **PULL SIDE** on the steering knuckle.

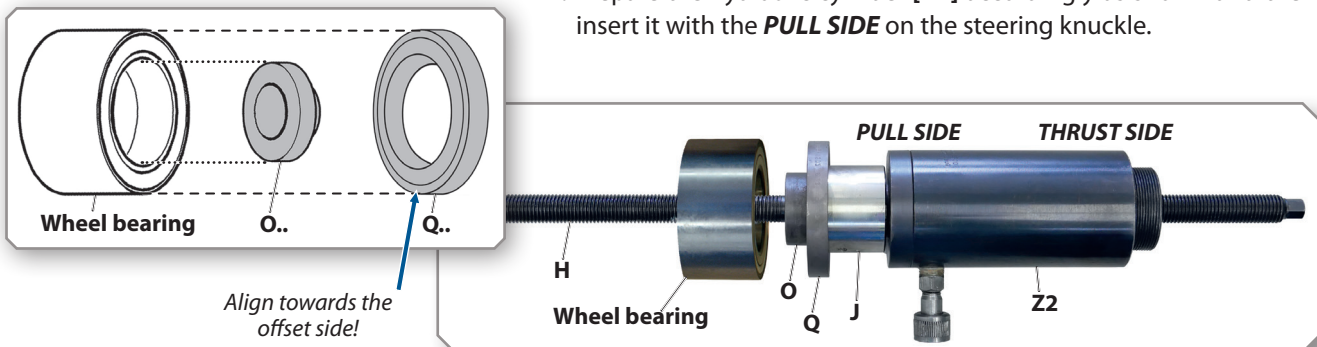

📷 41: Screw the clamping nut [K] onto the pull spindle [H] in the correct position...

3. Depending on the bore \varnothing on the steering knuckle, select a suitable thrust ring [Q..] which fits exactly on the shoulder on the inside of the steering knuckle.

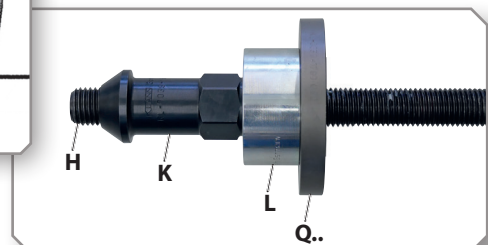
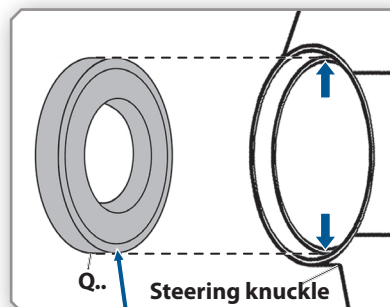
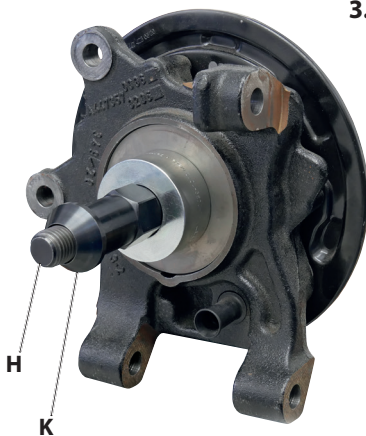

CAUTION

The pull spindle [H] can be torn out and damaged at the clamping nut [K].

► The clamping nut [K] **must** be screwed onto the pull spindle [H] until the thread protrudes at the back!

4. Place the adapter [L] together with the matching thrust ring [Q..] in the correct position on the pull spindle [H] as shown. Then screw the clamping nut [K] with the **flat side** in the correct position onto the pull spindle [H].

42: Press in the wheel bearing on the steering knuckle in the correct position according to the manufacturer's specifications...

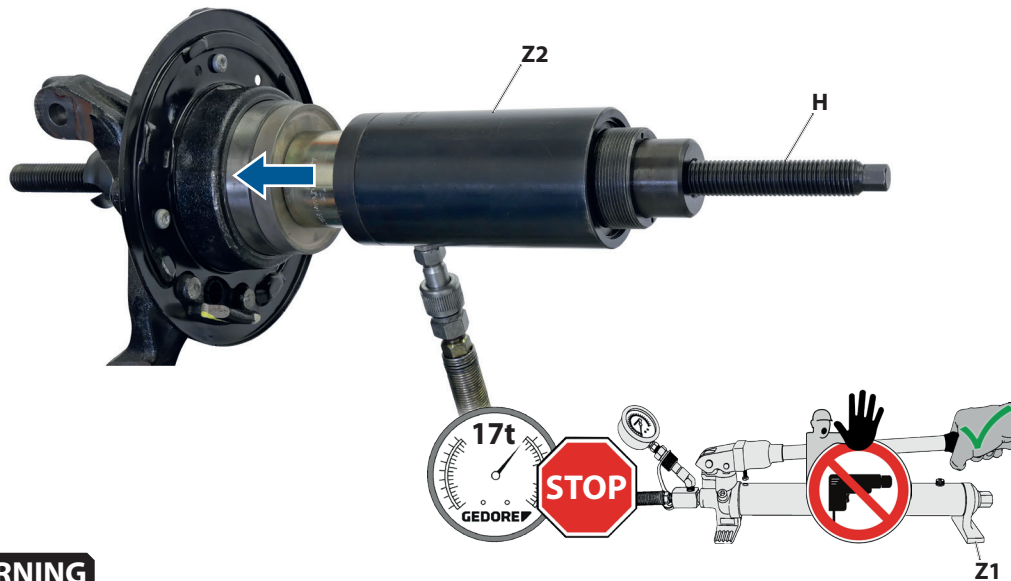

⚠ WARNING

The wheel bearing tool can break, fling around, and fall down when pressing in the wheel bearing. This can cause **DEATH** or **SEVERE INJURIES!**

- ▀ The **max. load** of the wheel bearing tool of **17 tons** must **never be exceeded!**
 - ▀ The pressure on the pressure gauge of the hydraulic pump **[Z1]** must **always** be observed during use!
 - ▀ During use, **never** stand in axial extension of the loaded pull spindle **[H]!**
 - ▀ The wheel bearing tool must **never** be used with a mechanical drive, e.g. an impulse or impact wrench or a drive other than that intended for it!
 - ▀ The wheel bearing tool **must** be secured against flinging around and falling down, for example by holding it or via the safety retaining belt - **KL-0040-2590** or the support device - **KL-0040-258 A**
5. Connect the hydraulic pump **[Z1]** with the hydraulic cylinder **[Z2]**. Operate the hydraulic pump **[Z1]**, observe the pressure on the pressure gauge and press the wheel bearing into the steering knuckle in the correct position according to the manufacturer's specifications.
- ① The maximum stroke of the hydraulic cylinder **[Z2]** is 45mm! As soon as it is reached: Interrupt the pressing process, release the pressure at the hydraulic pump **[Z1]**, turn the pull spindle **[K]** again, continue the pressing process.



6. Check the correct installation position of the wheel bearing according to the manufacturer's specifications, remove the wheel bearing tool and, if necessary, insert the wheel bearing retaining ring on the steering knuckle.

40: Prepare hydraulic cylinder [Z2] and attach to steering knuckle and secure...

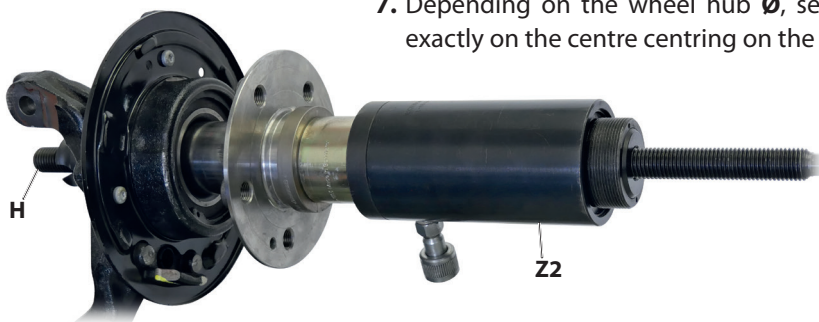

7. Depending on the wheel hub \varnothing , select a suitable thrust ring [P..], which fits exactly on the centre centring on the wheel hub.

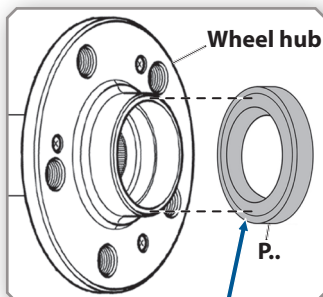

Align towards the offset side!

8. Prepare the hydraulic cylinder [Z2] accordingly as shown and insert it with the **PULL SIDE** on the wheel bearing.

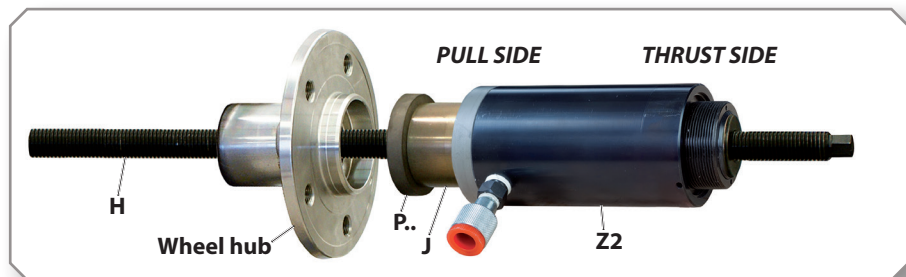

EN

41: Screw the clamping nut [K] onto the pull spindle [H] in the correct position...

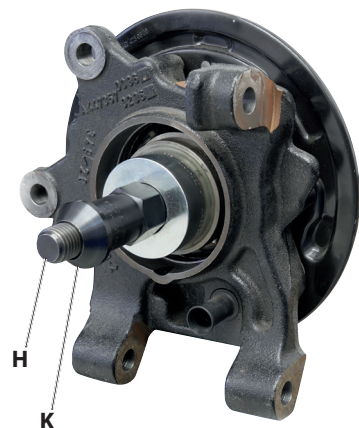

9. Depending on the wheel bearing \varnothing , select a suitable thrust ring [P..] which fits exactly on the inner ring on the wheel bearing.

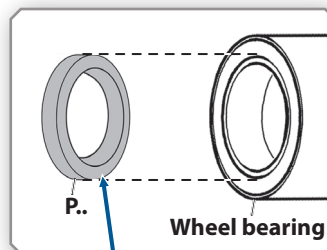

Align towards the flat side!

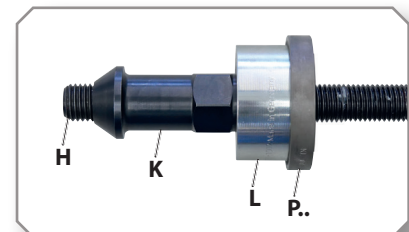

CAUTION

The pull spindle [H] can be torn out and damaged at the clamping nut [K].

► The clamping nut [K] **must** be screwed onto the pull spindle [H] until the thread protrudes at the back!

10. Place the adapter [L] together with the matching thrust ring [P..] in the correct position on the pull spindle [H] as shown. Then screw the clamping nut [K] with the flat side in the correct position onto the pull spindle [H].

45: Force in the wheel hub into the wheel bearing in the correct position according to manufacturer's specifications.

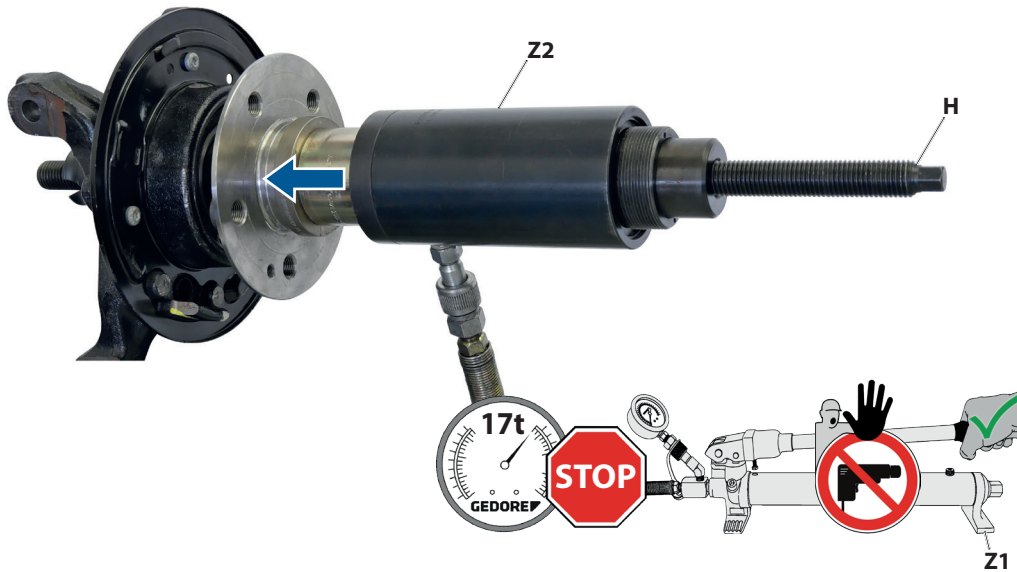

⚠ WARNING

The wheel bearing tool can break, fling around, and fall down when pressing in the wheel hub. This can cause **DEATH** or **SEVERE INJURIES!**

- ▀ The **max. load** of the wheel bearing tool of **17 tons** must **never be exceeded!**
- ▀ The pressure on the pressure gauge of the hydraulic pump **[Z1]** **must always** be observed during use!
- ▀ During use, **never** stand in axial extension of the loaded pull spindle **[H]!**
- ▀ The wheel bearing tool must **never** be used with a mechanical drive, e.g. an impulse or impact wrench or a drive other than that intended for it!
- ▀ The wheel bearing tool **must** be secured against flinging around and falling down, for example by holding it or via the safety retaining belt - **KL-0040-2590** or the support device - **KL-0040-258 A**

11. Connect the hydraulic pump **[Z1]** with the hydraulic cylinder **[Z2]**. Operate the hydraulic pump **[Z1]**, observe the pressure on the pressure gauge and press the wheel hub into the wheel bearing in the correct position according to the manufacturer's specifications.

① The maximum stroke of the hydraulic cylinder **[Z2]** is 45mm! As soon as it is reached: Interrupt the pressing process, release the pressure at the hydraulic pump **[Z1]**, turn the pull spindle **[K]** again, continue the pressing process.



12. Check the correct installation position of the wheel hub, remove the wheel bearing tool and reassemble the vehicle according to the manufacturer's specifications.

GEDORE-Werkzeugfabrik GmbH & Co. KG

Remscheider Straße 149
42899 - Remscheid
Postfach 120361
47873 Remscheid
GERMANY

Vertrieb DEUTSCHLAND

☎ +49 (0) 2191 / 596-0
☎ +49 (0) 2191 / 596-230
✉ info@gedore.com
🌐 www.gedore.com

Sales INTERNATIONAL

☎ +49 (0) 2191 / 596-910
☎ +49 (0) 2191 / 596-911
✉ info@gedore.com
🌐 www.gedore.com

GEDORE TOOLS, INC.

Only for USA, Canada & Mexico
Sólo para EE.UU., Canadá y México
Seulement pour les USA, le Canada et le Mexique
7187 Bryhawke Circle, Suite 700, North Charleston, SC 29418, USA

☎ +1-843 / 225 50 15
☎ +1-843 / 225 50 20
✉ info@gedoretools.com
🌐 www.gedoretools.com

Worldwide GEDORE service centers and offices are listed on the Internet at: www.gedore.com

GEDORE Automotive GmbH

Breslauer Straße 41
78166 - Donaueschingen
Postfach 1329
78154 Donaueschingen
GERMANY

Vertrieb DEUTSCHLAND

☎ +49 (0) 771 / 8 32 23-0
☎ +49 (0) 771 / 8 32 23-90
✉ info.gam@gedore.com
🌐 gedore-automotive.com



www.gedore-automotive.com